

**FEATURES**

- AD7705: 2 fully differential input channel ADCs**
- AD7706: 3 pseudo differential input channel ADCs**
- 16 bits no missing codes**
- 0.003% nonlinearity**
- Programmable gain front end**
- Gains from 1 to 128**
- 3-wire serial interface**
- SPI<sup>®</sup>-, QSPI<sup>™</sup>-, MICROWIRE<sup>™</sup>-, and DSP-compatible**
- Schmitt-trigger input on SCLK**
- Ability to buffer the analog input**
- 2.7 V to 3.3 V or 4.75 V to 5.25 V operation**
- Power dissipation 1 mW max @ 3 V**
- Standby current 8  $\mu$ A max**
- 16-lead PDIP, 16-lead SOIC, and 16-lead TSSOP packages**

**GENERAL DESCRIPTION**

The AD7705/AD7706<sup>1</sup> are complete analog front ends for low frequency measurement applications. These 2-/3-channel devices can accept low level input signals directly from a transducer and produce a serial digital output. They employ a  $\Sigma$ - $\Delta$  conversion technique to realize up to 16 bits of no missing codes performance. The selected input signal is applied to a proprietary, programmable-gain front end based around an analog modulator. The modulator output is processed by an on-chip digital filter. The first notch of this digital filter can be programmed via an on-chip control register, allowing adjustment of the filter cutoff and output update rate.

The AD7705/AD7706 operate from a single 2.7 V to 3.3 V or 4.75 V to 5.25 V supply. The AD7705 features two fully differential analog input channels, and the AD7706 features three pseudo differential input channels. Both devices feature a differential reference input. Input signal ranges of 0 mV to 20 mV through 0 V to 2.5 V can be incorporated on both devices when operating with a  $V_{DD}$  of 5 V and a reference of 2.5 V. They can also handle bipolar input signal ranges of  $\pm 20$  mV through  $\pm 2.5$  V, which are referenced to the AIN(-) inputs on the AD7705 and to the COMMON input on the AD7706. The AD7705/AD7706, with 3 V supply and a 1.225 V reference, can handle unipolar input signal ranges of 0 mV to 10 mV through 0 V to 1.225 V. Their bipolar input signal ranges are  $\pm 10$  mV through  $\pm 1.225$  V; therefore, the AD7705/AD7706 perform all signal conditioning and conversion for a 2-channel or 3-channel system.

**Rev. B**

Information furnished by Analog Devices is believed to be accurate and reliable. However, no responsibility is assumed by Analog Devices for its use, nor for any infringements of patents or other rights of third parties that may result from its use. Specifications subject to change without notice. No license is granted by implication or otherwise under any patent or patent rights of Analog Devices. Trademarks and registered trademarks are the property of their respective owners.

**FUNCTIONAL BLOCK DIAGRAM**

Figure 1.

The AD7705/AD7706 are ideal for use in smart, microcontroller, or DSP-based systems. They feature a serial interface that can be configured for 3-wire operation. Gain settings, signal polarity, and update rate selection can be configured in software using the input serial port. The part contains self-calibration and system calibration options to eliminate gain and offset errors on the part itself or in the system. CMOS construction ensures very low power dissipation, and the power-down mode reduces the standby power consumption to 20  $\mu$ W typ. These parts are available in a 16-lead, wide body (0.3 inch), plastic dual in-line package (DIP); a 16-lead, wide body (0.3 inch), standard small outline (SOIC) package; and a low profile, 16-lead, thin shrink small outline package (TSSOP).

<sup>1</sup> Protected by U.S. Patent Number 5,134,401.

## TABLE OF CONTENTS

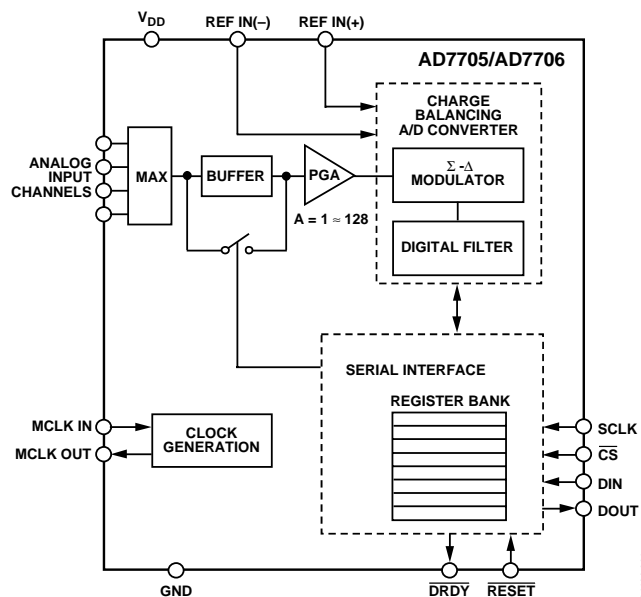
Product Highlights.....	3	Analog Filtering.....	24
Specifications.....	4	Calibration.....	24
Timing Characteristics .....	7	Theory of Operation .....	27
Absolute Maximum Ratings.....	8	Clocking and Oscillator Circuit .....	27
ESD Caution.....	8	System Synchronization .....	27
Pin Configurations and Function Descriptions .....	9	RESET Input .....	28
Output Noise (5 V Operation).....	11	Standby Mode .....	28
Output Noise (3 V Operation).....	12	Accuracy.....	28
Typical Performance Characteristics .....	13	Drift Considerations .....	28
On-Chip Registers .....	15	Power Supplies.....	29
Communication Register (RS2, RS1, RS0 = 0, 0, 0).....	15	Supply Current.....	29
Setup Register (RS2, RS1, RS0 = 0, 0, 1);		Grounding and Layout .....	29
Power-On/Reset Status: 01 Hex.....	16	Evaluating the Performance.....	30
Clock Register (RS2, RS1, RS0 = 0, 1, 0);		Digital Interface.....	30
Power-On/Reset Status: 05 Hex.....	17	Configuring The AD7705/AD7706.....	32
Data Register (RS2, RS1, RS0 = 0, 1, 1) .....	18	Microcomputer/Microprocessor Interfacing .....	33
Test Register (RS2, RS1, RS0 = 1, 0, 0);		Code For Setting Up The AD7705/AD7706.....	35
Power-On/Reset Status: 00 Hex.....	18	Applications.....	38
Zero-Scale Calibration Register (RS2, RS1, RS0 = 1, 1, 0);		Pressure Measurement.....	38
Power-On/Reset Status: 1F4000 Hex.....	19	Temperature Measurement .....	39
Full-Scale Calibration Register (RS2, RS1, RS0 = 1, 1, 1);		Smart Transmitters.....	40
Power-On/Reset Status: 5761AB Hex.....	19	Battery Monitoring .....	41
Circuit Description.....	20	Outline Dimensions .....	42
Analog Input .....	21	Ordering Guide .....	43
Bipolar/Unipolar Input.....	22		
Reference Input.....	22		
Digital Filtering.....	22		

## REVISION HISTORY

### 6/05—Rev. A to Rev. B

Updated Format.....	Universal
Changed Range of Absolute Voltage	
on Analog Inputs .....	Universal
Changes to Table 19.....	21
Updated Outline Dimensions .....	42
Changes to Ordering Guide .....	43

### 11/98—Rev. 0 to Rev. A

#### Revision 0: Initial Version

**PRODUCT HIGHLIGHTS**

1. The AD7705/AD7706 consume less than 1 mW at 3 V supplies and 1 MHz master clock, making them ideal for use in low power systems. Standby current is less than 8  $\mu$ A.
2. The programmable gain input allows the AD7705/AD7706 to accept input signals directly from a strain gage or transducer, removing a considerable amount of signal conditioning.
3. The AD7705/AD7706 are ideal for microcontroller or DSP processor applications with a 3-wire serial interface, reducing the number of interconnect lines and reducing the number of opto-couplers required in isolated systems.
4. The parts feature excellent static performance specifications with 16 bits, no missing codes,  $\pm 0.003\%$  accuracy, and low rms noise (<600 nV). Endpoint errors and the effects of temperature drift are eliminated by on-chip calibration options, which remove zero-scale and full-scale errors.

## SPECIFICATIONS

$V_{DD} = 3\text{ V}$  or  $5\text{ V}$ , REF IN(+) = 1.225 V with  $V_{DD} = 3\text{ V}$ , and 2.5 V with  $V_{DD} = 5\text{ V}$ ; REF IN(−) = GND; MCLK IN = 2.4576 MHz, unless otherwise noted. All specifications  $T_{MIN}$  to  $T_{MAX}$ , unless otherwise noted.

**Table 1.**

Parameter	B Version <sup>1</sup>	Unit	Conditions/Comments
<b>STATIC PERFORMANCE</b>			
No Missing Codes	16	Bits min	Guaranteed by design. Filter notch < 60 Hz.
Output Noise	See Table 5 and Table 7		Depends on filter cutoffs and selected gain.
Integral Nonlinearity <sup>2</sup>	±0.003	% of FSR max	Filter notch < 60 Hz. Typically ±0.0003%.
Unipolar Offset Error <sup>3</sup>			
Unipolar Offset Drift <sup>4</sup>	0.5	μV/°C typ	
Bipolar Zero Error <sup>3</sup>			
Bipolar Zero Drift <sup>4</sup>	0.5	μV/°C typ	For gains 1, 2, and 4.
	0.1	μV/°C typ	For gains 8, 16, 32, 64, and 128.
Positive Full-Scale Error <sup>3,5</sup>			
Full-Scale Drift <sup>4,6</sup>	0.5	μV/°C typ	
Gain Error <sup>3,7</sup>			
Gain Drift <sup>4,8</sup>	0.5	ppm of FSR/°C typ	
Bipolar Negative Full-Scale Error <sup>2</sup>	±0.003	% of FSR typ	Typically ±0.001%.
Bipolar Negative Full-Scale Drift <sup>4</sup>	1	μV/°C typ	For gains of 1 to 4.
	0.6	μV/°C typ	For gains of 8 to 128.
<b>ANALOG INPUTS/REFERENCE INPUTS</b>			
Common-Mode Rejection (CMR) <sup>2</sup>			Specifications for AIN and REF IN, unless otherwise noted.
$V_{DD} = 5\text{ V}$			
Gain = 1	96	dB typ	
Gain = 2	105	dB typ	
Gain = 4	110	dB typ	
Gain = 8 to 128	130	dB typ	
$V_{DD} = 3\text{ V}$			
Gain = 1	105	dB typ	
Gain = 2	110	dB typ	
Gain = 4	120	dB typ	
Gain = 8 to 128	130	dB typ	
Normal-Mode 50 Hz Rejection <sup>2</sup>	98	dB typ	For filter notches of 25 Hz, 50 Hz, $\pm 0.02 \times f_{NOTCH}$ .
Normal-Mode 60 Hz Rejection <sup>2</sup>	98	dB typ	For filter notches of 20 Hz, 60 Hz, $\pm 0.02 \times f_{NOTCH}$ .
Common-Mode 50 Hz Rejection <sup>2</sup>	150	dB typ	For filter notches of 25 Hz, 50 Hz, $\pm 0.02 \times f_{NOTCH}$ .
Common-Mode 60 Hz Rejection <sup>2</sup>	150	dB typ	For filter notches of 20 Hz, 60 Hz, $\pm 0.02 \times f_{NOTCH}$ .
Absolute/Common-Mode REF IN Voltage <sup>2</sup>	GND to $V_{DD}$	V min to V max	
Absolute/Common-Mode AIN Voltage <sup>2,9,10</sup>	GND – 100 mV	V min	BUF bit of setup register = 0.
	$V_{DD} + 30\text{ mV}$	V max	
Absolute/Common-Mode AIN Voltage <sup>2,9</sup>	GND + 50 mV	V min	BUF bit of setup register = 1.
	$V_{DD} - 1.5\text{ V}$	V max	
AIN DC Input Current <sup>2</sup>	1	nA max	
AIN Sampling Capacitance <sup>2</sup>	10	pF max	
AIN Differential Voltage Range <sup>11</sup>	0 to $+V_{REF}/GAIN$ <sup>12</sup>	nom	Unipolar input range ( $\overline{B}/U$ bit of setup register = 1).
	$\pm V_{REF}/GAIN$	nom	Bipolar input range ( $\overline{B}/U$ bit of setup register = 0).

Parameter	B Version <sup>1</sup>	Unit	Conditions/Comments
AIN Input Sampling Rate, $f_s$	$GAIN \times f_{CLKIN}/64$ $f_{CLKIN}/8$		For gains of 1 to 4. For gains of 8 to 128.
Reference Input Range			
REF IN(+) – REF IN(–) Voltage	1/1.75	V min/max	$V_{DD} = 2.7\text{ V to }3.3\text{ V}$ . $V_{REF} = 1.225 \pm 1\%$ for specified performance.
REF IN(+) – REF IN(–) Voltage	1/3.5	V min/max	$V_{DD} = 4.75\text{ V to }5.25\text{ V}$ . $V_{REF} = 2.5 \pm 1\%$ for specified performance.
REF IN Input Sampling Rate, $f_s$	$f_{CLKIN}/64$		
<b>LOGIC INPUTS</b>			
Input Current			
All Inputs, Except MCLK IN	$\pm 1$	$\mu\text{A max}$	Typically $\pm 20\text{ nA}$ .
MCLK IN	$\pm 10$	$\mu\text{A max}$	Typically $\pm 2\text{ }\mu\text{A}$ .
All Inputs, Except SCLK and MCLK IN			
Input Low Voltage, $V_{INL}$	0.8	V max	$V_{DD} = 5\text{ V}$ .
	0.4	V max	$V_{DD} = 3\text{ V}$ .
Input High Voltage, $V_{INH}$	2.0	V min	$V_{DD} = 3\text{ V and }5\text{ V}$ .
SCLK Only (Schmitt-Triggered Input)			$V_{DD} = 5\text{ V nominal}$ .
$V_{T+}$	1.4/3	V min/V max	
$V_{T-}$	0.8/1.4	V min/V max	
$V_{T+} - V_{T-}$	0.4/0.8	V min/V max	
SCLK Only (Schmitt-Triggered Input)			$V_{DD} = 3\text{ V nominal}$ .
$V_{T+}$	1/2	V min/V max	
$V_{T-}$	0.4/1.1	V min/V max	
$V_{T+} - V_{T-}$	0.375/0.8	V min/V max	
MCLK IN Only			$V_{DD} = 5\text{ V nominal}$ .
Input Low Voltage, $V_{INL}$	0.8	V max	
Input High Voltage, $V_{INH}$	3.5	V min	
MCLK IN Only			$V_{DD} = 3\text{ V nominal}$ .
Input Low Voltage, $V_{INL}$	0.4	V max	
Input High Voltage, $V_{INH}$	2.5	V min	
<b>LOGIC OUTPUTS (Including MCLK OUT)</b>			
Output Low Voltage, $V_{OL}$	0.4	V max	$I_{SINK} = 800\text{ }\mu\text{A}$ , except for MCLK OUT. <sup>13</sup> $V_{DD} = 5\text{ V}$ .
Output Low Voltage, $V_{OL}$	0.4	V max	$I_{SINK} = 100\text{ }\mu\text{A}$ , except for MCLK OUT. <sup>13</sup> $V_{DD} = 3\text{ V}$ .
Output High Voltage, $V_{OH}$	4	V min	$I_{SOURCE} = 200\text{ }\mu\text{A}$ , except for MCLK OUT. <sup>13</sup> $V_{DD} = 5\text{ V}$ .
Output High Voltage, $V_{OH}$	$V_{DD} - 0.6$	V min	$I_{SOURCE} = 100\text{ }\mu\text{A}$ , except for MCLK OUT. <sup>13</sup> $V_{DD} = 3\text{ V}$ .
Floating State Leakage Current	$\pm 10$	$\mu\text{A max}$	
Floating State Output Capacitance <sup>14</sup>	9	pF typ	
Data Output Coding	Binary		Unipolar mode.
	Offset binary		Bipolar mode.
<b>SYSTEM CALIBRATION</b>			
Positive Full-Scale Limit <sup>15</sup>	$(1.05 \times V_{REF})/GAIN$	V max	GAIN is the selected PGA gain (1 to 128).
Negative Full-Scale Limit <sup>15</sup>	$-(1.05 \times V_{REF})/GAIN$	V max	GAIN is the selected PGA gain (1 to 128).
Offset Limit <sup>15</sup>	$-(1.05 \times V_{REF})/GAIN$	V max	GAIN is the selected PGA gain (1 to 128).
Input Span <sup>16</sup>	$(0.8 \times V_{REF})/GAIN$	V min	GAIN is the selected PGA gain (1 to 128).
	$(2.1 \times V_{REF})/GAIN$	V max	GAIN is the selected PGA gain (1 to 128).

# AD7705/AD7706

Parameter	B Version <sup>1</sup>	Unit	Conditions/Comments
<b>POWER REQUIREMENTS</b>			
V <sub>DD</sub> Voltage	2.7 to 3.3	V min to V max	For specified performance.
Power Supply Currents <sup>17</sup>	0.32	mA max	Digital I/Ps = 0 V or V <sub>DD</sub> . External MCLK IN and CLKDIS = 1. BUF bit = 0. f <sub>CLKIN</sub> = 1 MHz. Gains of 1 to 128.
	0.6	mA max	BUF bit = 1. f <sub>CLKIN</sub> = 1 MHz. Gains of 1 to 128.
	0.4	mA max	BUF bit = 0. f <sub>CLKIN</sub> = 2.4576 MHz. Gains of 1 to 4.
	0.6	mA max	BUF bit = 0. f <sub>CLKIN</sub> = 2.4576 MHz. Gains of 8 to 128.
	0.7	mA max	BUF bit = 1. f <sub>CLKIN</sub> = 2.4576 MHz. Gains of 1 to 4.
	1.1	mA max	BUF bit = 1. f <sub>CLKIN</sub> = 2.4576 MHz. Gains of 8 to 128.
V <sub>DD</sub> Voltage	4.75 to 5.25	V min to V max	For specified performance.
Power Supply Currents <sup>17</sup>	0.45	mA max	Digital I/Ps = 0 V or V <sub>DD</sub> . External MCLK IN and CLKDIS = 1. BUF bit = 0. f <sub>CLKIN</sub> = 1 MHz. Gains of 1 to 128.
	0.7	mA max	BUF bit = 1. f <sub>CLKIN</sub> = 1 MHz. Gains of 1 to 128.
	0.6	mA max	BUF bit = 0. f <sub>CLKIN</sub> = 2.4576 MHz. Gains of 1 to 4.
	0.85	mA max	BUF bit = 0. f <sub>CLKIN</sub> = 2.4576 MHz. Gains of 8 to 128.
	0.9	mA max	BUF bit = 1. f <sub>CLKIN</sub> = 2.4576 MHz. Gains of 1 to 4.
	1.3	mA max	BUF bit = 1. f <sub>CLKIN</sub> = 2.4576 MHz. Gains of 8 to 128.
Standby (Power-Down) Current <sup>18</sup>	16	μA max	External MCLK IN = 0 V or V <sub>DD</sub> . V <sub>DD</sub> = 5 V. See Figure 12.
	8	μA max	External MCLK IN = 0 V or V <sub>DD</sub> . V <sub>DD</sub> = 3 V.
Power Supply Rejection <sup>19,20</sup>		dB typ	

<sup>1</sup> Temperature range is -40°C to +85°C.

<sup>2</sup> These numbers are established from characterization or design data at initial product release.

<sup>3</sup> A calibration is effectively a conversion; therefore, these errors are of the order of the conversion noise shown in Table 5 and Table 7. This applies after calibration at the temperature of interest.

<sup>4</sup> Recalibration at any temperature removes these drift errors.

<sup>5</sup> Positive full-scale error includes zero-scale errors (unipolar offset error or bipolar zero error) and applies to both unipolar and bipolar input ranges.

<sup>6</sup> Full-scale drift includes zero-scale drift (unipolar offset drift or bipolar zero drift) and applies to both unipolar and bipolar input ranges.

<sup>7</sup> Gain error does not include zero-scale errors. It is calculated as full-scale error - unipolar offset error for unipolar ranges and full-scale error - bipolar zero error for bipolar ranges.

<sup>8</sup> Gain drift does not include unipolar offset drift or bipolar zero drift. It is effectively the drift of the part if only zero-scale calibrations are performed.

<sup>9</sup> This common-mode voltage range is allowed, provided that the input voltage on analog inputs is not more positive than V<sub>DD</sub> + 30 mV or more negative than GND - 100 mV. Parts are functional with voltages down to GND - 200 mV, but with increased leakage at high temperatures.

<sup>10</sup> The AD7705/AD7706 can tolerate absolute analog input voltages down to GND - 200 mV, but the leakage current increases.

<sup>11</sup> The analog input voltage range on AIN(+) is given with respect to the voltage on AIN(-) on the AD7705, and with respect to the voltage of the COMMON input on the AD7706. The absolute voltage on the analog inputs should not be more positive than V<sub>DD</sub> + 30 mV, or more negative than GND - 100 mV for specified performance. Input voltages of GND - 200 mV can be accommodated, but with increased leakage at high temperatures.

<sup>12</sup> V<sub>REF</sub> = REF IN(+) - REF IN(-).

<sup>13</sup> These logic output levels apply to the MCLK OUT only when it is loaded with one CMOS load.

<sup>14</sup> Sample tested at 25°C to ensure compliance.

<sup>15</sup> After calibration, if the analog input exceeds positive full scale, the converter outputs all 1s. If the analog input is less than negative full scale, the device outputs all 0s.

<sup>16</sup> These calibration and span limits apply, provided that the absolute voltage on the analog inputs does not exceed V<sub>DD</sub> + 30 mV or go more negative than GND - 100 mV. The offset calibration limit applies to both the unipolar zero point and the bipolar zero point.

<sup>17</sup> When using a crystal or ceramic resonator across the MCLK pins as the clock source for the device, the V<sub>DD</sub> current and power dissipation varies depending on the crystal or resonator type (see Clocking and Oscillator Circuit section).

<sup>18</sup> If the external master clock continues to run in standby mode, the standby current increases to 150 μA typical at 5 V and 75 μA at 3 V. When using a crystal or ceramic resonator across the MCLK pins as the clock source for the device, the internal oscillator continues to run in standby mode, and the power dissipation depends on the crystal or resonator type (see Standby Mode section).

<sup>19</sup> Measured at dc and applies in the selected pass band. PSRR at 50 Hz exceeds 120 dB, with filter notches of 25 Hz or 50 Hz. PSRR at 60 Hz exceeds 120 dB, with filter notches of 20 Hz or 60 Hz.

<sup>20</sup> PSRR depends on both gain and V<sub>DD</sub>, as follows:

Gain	1	2	4	8 to 128
V <sub>DD</sub> = 3 V	86	78	85	93
V <sub>DD</sub> = 5 V	90	78	84	91

## TIMING CHARACTERISTICS

$V_{DD} = 2.7 \text{ V to } 5.25 \text{ V}$ ;  $GND = 0 \text{ V}$ ;  $f_{CLKIN} = 2.4576 \text{ MHz}$ ; Input Logic 0 = 0 V, Logic 1 =  $V_{DD}$ , unless otherwise noted.

Table 2. Timing Characteristics<sup>1,2</sup>

Parameter	Limit at $T_{MIN}$ , $T_{MAX}$ (B Version)	Unit	Conditions/Comments
$f_{CLKIN}^{3,4}$	400 2.5	kHz min MHz max	Master clock frequency (crystal oscillator or externally supplied). For specified performance.
$t_{CLKIN LO}$	$0.4 \times t_{CLKIN}$	ns min	Master clock input low time, $t_{CLKIN} = 1/f_{CLKIN}$ .
$t_{CLKIN HI}$	$0.4 \times t_{CLKIN}$	ns min	Master clock input high time.
$t_1$	$500 \times t_{CLKIN}$	ns nom	$\overline{DRDY}$ high time.
$t_2$	100	ns min	$\overline{RESET}$ pulse width.
Read Operation			
$t_3$	0	ns min	$\overline{DRDY}$ to $\overline{CS}$ setup time.
$t_4$	120	ns min	$\overline{CS}$ falling edge to SCLK rising edge setup time.
$t_5^5$	0	ns min	SCLK falling edge to data valid delay.
	80	ns max	$V_{DD} = 5 \text{ V}$ .
	100	ns max	$V_{DD} = 3.0 \text{ V}$ .
$t_6$	100	ns min	SCLK high pulse width.
$t_7$	100	ns min	SCLK low pulse width.
$t_8$	0	ns min	$\overline{CS}$ rising edge to SCLK rising edge hold time.
$t_9^6$	10	ns min	Bus relinquish time after SCLK rising edge.
	60	ns max	$V_{DD} = 5 \text{ V}$ .
	100	ns max	$V_{DD} = 3.0 \text{ V}$ .
$t_{10}$	100	ns max	SCLK falling edge to $\overline{DRDY}$ high. <sup>7</sup>
Write Operation			
$t_{11}$	120	ns min	$\overline{CS}$ falling edge to SCLK rising edge setup time.
$t_{12}$	30	ns min	Data valid to SCLK rising edge setup time.
$t_{13}$	20	ns min	Data valid to SCLK rising edge hold time.
$t_{14}$	100	ns min	SCLK high pulse width.
$t_{15}$	100	ns min	SCLK low pulse width.
$t_{16}$	0	ns min	$\overline{CS}$ rising edge to SCLK rising edge hold time.

<sup>1</sup> Sample tested at 25°C to ensure compliance. All input signals are specified with  $t_R = t_F = 5 \text{ ns}$  (10% to 90% of  $V_{DD}$ ) and timed from a voltage level of 1.6 V.

<sup>2</sup> See Figure 19 and Figure 20.

<sup>3</sup> The  $f_{CLKIN}$  duty cycle range is 45% to 55%.  $f_{CLKIN}$  must be supplied whenever the AD7705/AD7706 are not in standby mode. If no clock is present, the devices can draw higher current than specified, and possibly become uncalibrated.

<sup>4</sup> The AD7705/AD7706 are production tested with  $f_{CLKIN}$  at 2.4576 MHz (1 MHz for some  $I_{DD}$  tests). They are guaranteed by characterization to operate at 400 kHz.

<sup>5</sup> These numbers are measured with the load circuit of Figure 2 and defined as the time required for the output to cross the  $V_{OL}$  or  $V_{OH}$  limits.

<sup>6</sup> These numbers are derived from the measured time taken by the data output to change 0.5 V when loaded with the circuit of Figure 2. The measured number is then extrapolated back to remove effects of charging or discharging the 50 pF capacitor. This means that the times quoted in the timing characteristics are the true bus relinquish times of the part and as such are independent of external bus loading capacitances.

<sup>7</sup>  $\overline{DRDY}$  returns high upon completion of the first read from the device after an output update. The same data can be reread while  $\overline{DRDY}$  is high, but care should be taken that subsequent reads do not occur close to the next output update.

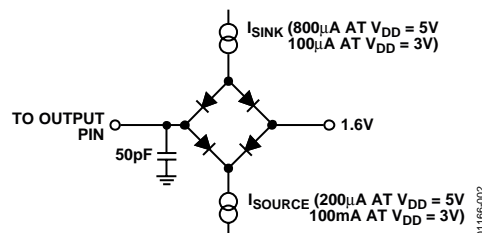

Figure 2. Load Circuit for Access Time and Bus Relinquish Time

## ABSOLUTE MAXIMUM RATINGS

$T_A = 25^\circ\text{C}$ , unless otherwise noted.

**Table 3.**

Parameters	Ratings
$V_{DD}$ to GND	-0.3 V to +7 V
Analog Input Voltage to GND	-0.3 V to $V_{DD} + 0.3$ V
Reference Input Voltage to GND	-0.3 V to $V_{DD} + 0.3$ V
Digital Input Voltage to GND	-0.3 V to $V_{DD} + 0.3$ V
Digital Output Voltage to GND	-0.3 V to $V_{DD} + 0.3$ V
Operating Temperature Range	
Commercial (B Version)	-40°C to +85°C
Storage Temperature Range	-65°C to +150°C
Junction Temperature	150°C
PDIP Package, Power Dissipation	450 mW
$\theta_{JA}$ Thermal Impedance	105°C/W
Lead Temperature (Soldering, 10 sec)	260°C
SOIC Package, Power Dissipation	450 mW
$\theta_{JA}$ Thermal Impedance	75°C/W
Lead Temperature, Soldering	
Vapor Phase (60 sec)	215°C
Infrared (15 sec)	220°C
SSOP Package, Power Dissipation	450 mW
$\theta_{JA}$ Thermal Impedance	139°C/W
Lead Temperature, Soldering	
Vapor Phase (60 sec)	215°C
Infrared (15 sec)	220°C
ESD Rating	>4000 V

Stresses above those listed under Absolute Maximum Ratings may cause permanent damage to the device. This is a stress rating only; functional operation of the device at these or any other conditions above those indicated in the operational section of this specification is not implied. Exposure to absolute maximum rating conditions for extended periods may affect device reliability.

### ESD CAUTION

ESD (electrostatic discharge) sensitive device. Electrostatic charges as high as 4000 V readily accumulate on the human body and test equipment and can discharge without detection. Although this product features proprietary ESD protection circuitry, permanent damage may occur on devices subjected to high energy electrostatic discharges. Therefore, proper ESD precautions are recommended to avoid performance degradation or loss of functionality.





## PIN CONFIGURATIONS AND FUNCTION DESCRIPTIONS

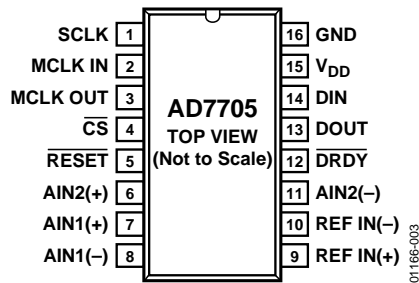

Figure 3. AD7705 Pin Configuration

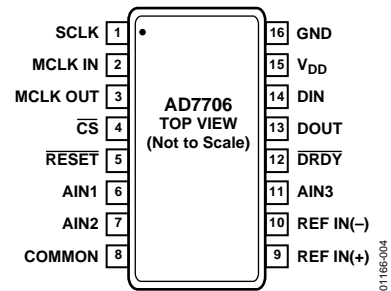

Figure 4. AD7706 Pin Configuration

Table 4. Pin Function Descriptions

Pin No.	Mnemonic		Description
	AD7705	AD7706	
1	SCLK	SCLK	Serial Clock. An external serial clock is applied to the Schmitt-triggered logic input to access serial data from the AD7705/AD7706. This serial clock can be a continuous clock with all data transmitted in a continuous train of pulses. Alternatively, it can be a noncontinuous clock with the information transmitted to the AD7705/AD7706 in smaller batches of data.
2	MCLK IN	MCLK IN	Master Clock Signal. This can be provided in the form of a crystal/resonator or external clock. A crystal/resonator can be tied across the MCLK IN and MCLK OUT pins. Alternatively, the MCLK IN pin can be driven with a CMOS-compatible clock with MCLK OUT left unconnected. The parts can be operated with clock frequencies in the range 500 kHz to 5 MHz.
3	MCLK OUT	MCLK OUT	When the master clock for these devices is a crystal/resonator, the crystal/resonator is connected between MCLK IN and MCLK OUT. If an external clock is applied to MCLK IN, MCLK OUT provides an inverted clock signal. This clock can be used to provide a clock source for external circuitry and is capable of driving 1 CMOS load. If the user does not require this clock externally, MCLK OUT can be turned off via the CLKDIS bit of the clock register. This ensures that the part does not unnecessarily burn power driving capacitive loads on MCLK OUT.
4	$\overline{\text{CS}}$	$\overline{\text{CS}}$	Chip Select. Active low logic input used to select the AD7705/AD7706. With this input hardwired low, the AD7705/AD7706 can operate in its 3-wire interface mode with SCLK, DIN, and DOUT used to interface to the device. $\overline{\text{CS}}$ can be used to select the device communicating with the AD7705/AD7706.
5	$\overline{\text{RESET}}$	$\overline{\text{RESET}}$	Logic Input. Active low input that resets the control logic, interface logic, calibration coefficients, digital filter, and analog modulator of the parts to power-on status.
6	AIN2(+)	AIN1	Positive Input of the Differential Analog Input Channel 2 for AD7705; Channel 1 for AD7706.
7	AIN1(+)	AIN2	Positive Input of the Differential Analog Input Channel 1 for AD7705; Channel 2 for AD7706.
8	AIN1(-)	COMMON	Negative Input of the Differential Analog Input Channel 1 for AD7705; COMMON input for AD7706 with Channels 1, 2, and 3 being referenced to this input.
9	REF IN(+)	REF IN(+)	Reference Input. Positive input of the differential reference input to the AD7705/AD7706. The reference input is differential with the provision that REF IN(+) must be greater than REF IN(-). REF IN(+) can lie anywhere between $V_{DD}$ and GND.
10	REF IN(-)	REF IN(-)	Reference Input. Negative input of the differential reference input to the AD7705/AD7706. The REF IN(-) can lie anywhere between $V_{DD}$ and GND, provided that REF IN(+) is greater than REF IN(-).
11	AIN2(-)	AIN3	Negative Input of the Differential Analog Input. Channel 2 for AD7705; Channel 3 for AD7706.

# AD7705/AD7706

Pin No.	Mnemonic		Description
	AD7705	AD7706	
12	$\overline{\text{DRDY}}$	$\overline{\text{DRDY}}$	Logic Output. A logic low on this output indicates that a new output word is available from the AD7705/AD7706 data register. The $\overline{\text{DRDY}}$ pin returns high upon completion of a read operation of a full output word. If no data read has taken place between output updates, the $\overline{\text{DRDY}}$ line returns high for $500 \times t_{\text{CLKIN}}$ cycles prior to the next output update. While $\overline{\text{DRDY}}$ is high, a read operation should neither be attempted nor in progress to avoid reading from the data register as it is being updated. The $\overline{\text{DRDY}}$ line returns low after the update has taken place. $\overline{\text{DRDY}}$ is also used to indicate when the AD7705/AD7706 has completed its on-chip calibration sequence.
13	DOUT	DOUT	Serial Data Output. Serial data is read from the output shift register on the part. The output shift register can contain information from the setup register, communication register, clock register, or data register, depending on the register selection bits of the communication register.
14	DIN	DIN	Serial Data Input. Serial data is written to the input shift register on the part. Data from the input shift register is transferred to the setup register, clock register, or communication register, depending on the register selection bits of the communication register.
15	V <sub>DD</sub>	V <sub>DD</sub>	Supply Voltage. 2.7 V to 5.25 V operation.
16	GND	GND	Ground reference point for the AD7705/AD7706 internal circuitry.

## OUTPUT NOISE (5 V OPERATION)

Table 5 shows the AD7705/AD7706 output rms noise for the selectable notch and  $-3$  dB frequencies for the parts, as selected by FS0 and FS1 of the clock register. The numbers given are for the bipolar input ranges with a  $V_{REF}$  of 2.5 V and  $V_{DD} = 5$  V. These numbers are typical and are generated at an analog input voltage of 0 V with the parts used in either buffered or unbuffered mode. Table 6 shows the output peak-to-peak noise for the selectable notch and  $-3$  dB frequencies for the parts. It is

important to note that these numbers represent the resolution for which there is no code flicker. They are not calculated based on rms noise, but on peak-to-peak noise. The numbers given are for bipolar input ranges with a  $V_{REF}$  of 2.5 V for either buffered or unbuffered mode. These numbers are typical and are rounded to the nearest LSB. The numbers apply for the CLKDIV bit of the clock register set to 0.

**Table 5. Output RMS Noise vs. Gain and Output Update Rate @ 5 V**

Filter's First Notch and O/P Data Rate	$-3$ dB Frequency	Typical Output RMS Noise in $\mu$ V							
		Gain of 1	Gain of 2	Gain of 4	Gain of 8	Gain of 16	Gain of 32	Gain of 64	Gain of 128
MCLK IN = 2.4576 MHz									
50 Hz	13.1 Hz	4.1	2.1	1.2	0.75	0.7	0.66	0.63	0.6
60 Hz	15.72 Hz	5.1	2.5	1.4	0.8	0.75	0.7	0.67	0.62
250 Hz	65.5 Hz	110	49	31	17	8	3.6	2.3	1.7
500 Hz	131 Hz	550	285	145	70	41	22	9.1	4.7
MCLK IN = 1 MHz									
20 Hz	5.24 Hz	4.1	2.1	1.2	0.75	0.7	0.66	0.63	0.6
25 Hz	6.55 Hz	5.1	2.5	1.4	0.8	0.75	0.7	0.67	0.62
100 Hz	26.2 Hz	110	49	31	17	8	3.6	2.3	1.7
200 Hz	52.4 Hz	550	285	145	70	41	22	9.1	4.7

**Table 6. Peak-to-Peak Resolution vs. Gain and Output Update Rate @ 5 V**

Filter's First Notch and O/P Data Rate	$-3$ dB Frequency	Typical Peak-to-Peak Resolution Bits							
		Gain of 1	Gain of 2	Gain of 4	Gain of 8	Gain of 16	Gain of 32	Gain of 64	Gain of 128
MCLK IN = 2.4576 MHz									
50 Hz	13.1 Hz	16	16	16	16	16	16	15	14
60 Hz	15.72 Hz	16	16	16	16	15	14	14	13
250 Hz	65.5 Hz	13	13	13	13	13	13	12	12
500 Hz	131 Hz	10	10	10	10	10	10	10	10
MCLK IN = 1 MHz									
20 Hz	5.24 Hz	16	16	16	16	16	16	15	14
25 Hz	6.55 Hz	16	16	16	16	15	14	14	13
100 Hz	26.2 Hz	13	13	13	13	13	13	12	12
200 Hz	52.4 Hz	10	10	10	10	10	10	10	10

## OUTPUT NOISE (3 V OPERATION)

Table 7 shows the AD7705/AD7706 output rms noise for the selectable notch and -3 dB frequencies for the parts, as selected by FS0 and FS1 of the clock register. The numbers given are for the bipolar input ranges with a  $V_{REF}$  of 1.225 V and a  $V_{DD} = 3$  V. These numbers are typical and are generated at an analog input voltage of 0 V with the parts used in either buffered or unbuffered mode. Table 6 shows the output peak-to-peak noise for the selectable notch and -3 dB frequencies for the parts. It is

important to note that these numbers represent the resolution for which there is no code flicker. They are not calculated based on rms noise, but on peak-to-peak noise. The numbers given are for bipolar input ranges with a  $V_{REF}$  of 1.225 V for either buffered or unbuffered mode. These numbers are typical and are rounded to the nearest LSB. The numbers apply for the CLKDIV bit of the clock register set to 0.

**Table 7. Output RMS Noise vs. Gain and Output Update Rate @ 3 V**

Filter's First Notch and O/P Data Rate	-3 dB Frequency	Typical Output RMS Noise in $\mu$ V							
		Gain of 1	Gain of 2	Gain of 4	Gain of 8	Gain of 16	Gain of 32	Gain of 64	Gain of 128
MCLK IN = 2.4576 MHz									
50 Hz	13.1 Hz	3.8	2.4	1.5	1.3	1.1	1.0	0.9	0.9
60 Hz	15.72 Hz	5.1	2.9	1.7	1.5	1.2	1.0	0.9	0.9
250 Hz	65.5 Hz	50	25	14	9.9	5.1	2.6	2.3	2.0
500 Hz	131 Hz	270	135	65	41	22	9.7	5.1	3.3
MCLK IN = 1 MHz									
20 Hz	5.24 Hz	3.8	2.4	1.5	1.3	1.1	1.0	0.9	0.9
25 Hz	6.55 Hz	5.1	2.9	1.7	1.5	1.2	1.0	0.9	0.9
100 Hz	26.2 Hz	50	25	14	9.9	5.1	2.6	2.3	2.0
200 Hz	52.4 Hz	270	135	65	41	22	9.7	5.1	3.3

**Table 8. Peak-to-Peak Resolution vs. Gain and Output Update Rate @ 3 V**

Filter's First Notch and O/P Data Rate	-3 dB Frequency	Typical Peak-to-Peak Resolution in Bits							
		Gain of 1	Gain of 2	Gain of 4	Gain of 8	Gain of 16	Gain of 32	Gain of 64	Gain of 128
MCLK IN = 2.4576 MHz									
50 Hz	13.1 Hz	16	16	15	15	14	13	13	12
60 Hz	15.72 Hz	16	16	15	14	14	13	13	12
250 Hz	65.5 Hz	13	13	13	13	12	12	11	11
500 Hz	131 Hz	10	10	10	10	10	10	10	10
MCLK IN = 1 MHz									
20 Hz	5.24 Hz	16	16	15	15	14	13	13	12
25 Hz	6.55 Hz	16	16	15	14	14	13	13	12
100 Hz	26.2 Hz	13	13	13	13	12	12	11	11
200 Hz	52.4 Hz	10	10	10	10	10	10	10	10

# TYPICAL PERFORMANCE CHARACTERISTICS

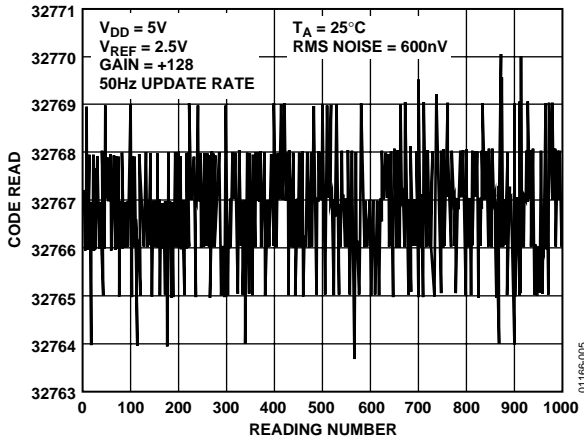

Figure 5. Noise @ Gain = 128 With 50 Hz Update Rate

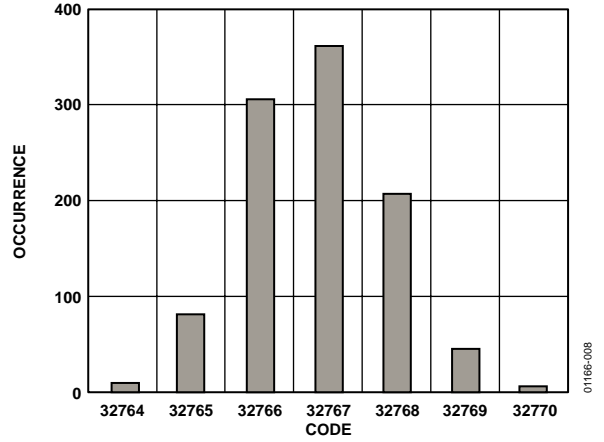

Figure 8. Histogram of Data in Figure 5

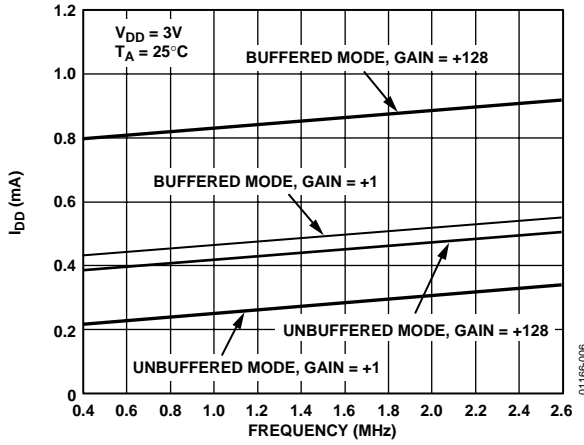

Figure 6.  $I_{DD}$  vs. MCLK IN Frequency @ 3 V

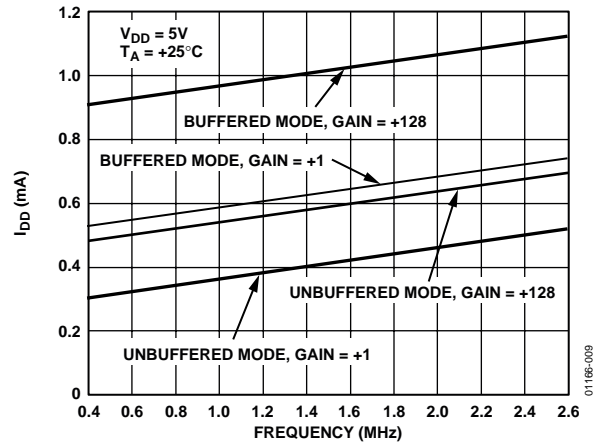

Figure 9.  $I_{DD}$  vs. MCLK IN Frequency @ 5 V

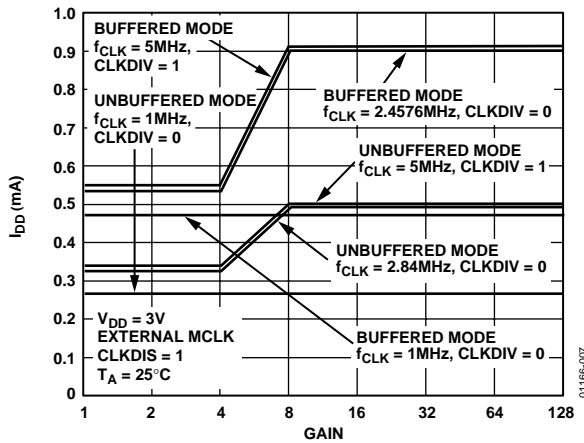

Figure 7.  $I_{DD}$  vs. Gain and Clock Frequency @ 3 V

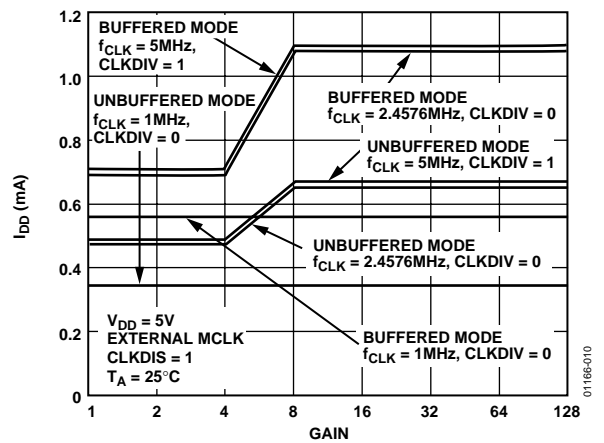

Figure 10.  $I_{DD}$  vs. Gain and Clock Frequency @ 5 V

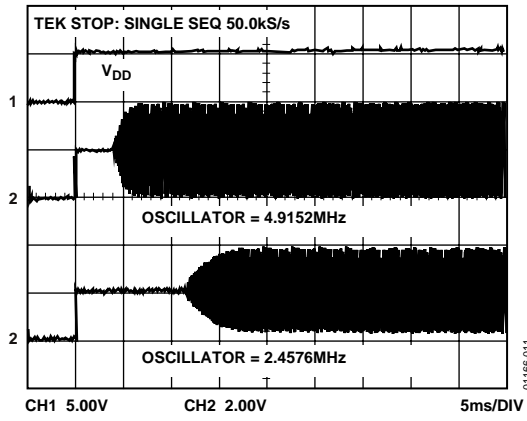

Figure 11. Crystal Oscillator Power-Up Time

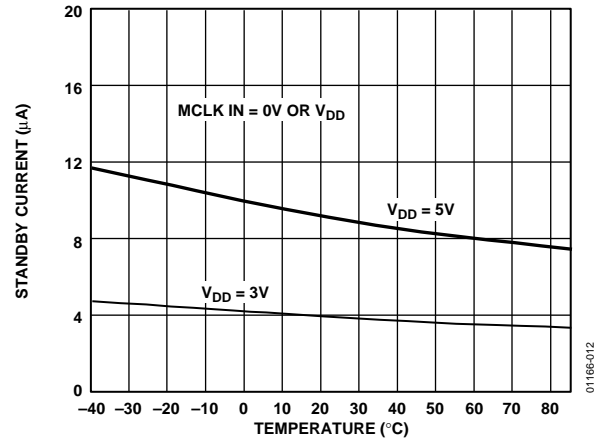

Figure 12. Standby Current vs. Temperature

## ON-CHIP REGISTERS

The AD7705/AD7706 each contain eight on-chip registers that can be accessed via the serial port. The first of these is a communication register that controls the channel selection, decides whether the next operation is a read or write operation, and decides which register the next read or write operation accesses. All communication to the part must start with a write operation to the communication register. After a power-on or reset, the device expects a write to its communication register. The data written to this register determines whether the next operation is a read or write operation and to which register this operation occurs. Therefore, write access to any register on the part starts with a write operation to the communication register, followed by a write to the selected register. Likewise, a read operation from any register on the part, including the communication register itself and the output data register, starts with a write operation to the communication register, followed by a read operation from the selected register. The communication register also controls the standby mode and channel selection. The  $\overline{\text{DRDY}}$  status is available by reading from the communication register. The second register is a setup register that determines calibration mode, gain setting, bipolar/unipolar operation, and buffered mode. The third register is labeled the clock register and contains the filter selection bits and clock control bits. The fourth register is the data register from which the output data is accessed. The final registers are the calibration registers, which store channel calibration data. The registers are discussed in more detail in the following sections.

### COMMUNICATION REGISTER (RS2, RS1, RS0 = 0, 0, 0)

The communication register is an 8-bit register from which data can be read or to which data can be written. All communication to the part must start with a write operation to its communication register. The data written to the communication register determines whether the next operation is a read or write operation and to which register this operation takes place. After the read or write operation is complete, the interface returns to its default state, where it expects a write operation to the communication register. In situations where the interface sequence is lost, a write operation of a least 32 serial clock cycles with DIN high returns the ADC to its default state by resetting the part. Table 9 outlines the bit designations for the communication register.

**Table 9. Communication Register**

$0/\overline{\text{DRDY}}$ (0)	RS2 (0)	RS1 (0)	RS0 (0)	$\overline{\text{R/W}}$ (0)	STBY (0)	CH1 (0)	CH0 (0)
$0/\overline{\text{DRDY}}$	For a write operation to the communications register, a 0 must be written to this bit. If a 1 is written to this bit, the part does not clock subsequent bits into the register. It stays at this bit location until a 0 is written to this bit. Then, the next seven bits are loaded into the communication register. For a read operation, this bit provides the status of the $\overline{\text{DRDY}}$ flag, which is the same as the $\overline{\text{DRDY}}$ output pin.						
RS2–RS0	Register Selection Bits. These bits are used to select which of the AD7705/AD7706 registers are being accessed during the serial interface communication.						
$\overline{\text{R/W}}$	Read/ $\overline{\text{WRITE}}$ Select. This bit selects whether the next operation is a read or write operation. A 0 indicates a write cycle for the next operation to the selected register, and a 1 indicates a read operation from the selected register.						
STBY	Standby. Writing 1 to this bit puts the part into standby or power-down mode. In this mode, the part consumes only 10 $\mu\text{A}$ of power supply current. The part retains its calibration coefficients and control word information when in standby. Writing 0 to this bit places the parts in normal operating mode.						
CH1, CH0	Channel Select. These two bits select a channel for conversion or for access to the calibration coefficients, as outlined in Table 11. Following a calibration on a channel, three pairs of calibration registers store the calibration coefficients. Table 11 for the AD7705 and Table 12 for the AD7706 show which channel combinations have independent calibration coefficients. With CH1 at Logic 1 and CH0 at Logic 0, AD7705 looks at the AIN1(–) input internally shorted to itself, and AD7706 looks at the COMMON input internally shorted to itself. This can be used as a test method to evaluate the noise performance of the parts with no external noise sources. In this mode, the AIN1(–)/COMMON input should be connected to an external voltage within the allowable common-mode range for the parts.						

# AD7705/AD7706

**Table 10. Register Selection**

RS2	RS1	RS0	Register	Register Size
0	0	0	Communication register	8 bits
0	0	1	Setup register	8 bits
0	1	0	Clock register	8 bits
0	1	1	Data register	16 bits
1	0	0	Test register	8 bits
1	0	1	No operation	
1	1	0	Offset register	24 bits
1	1	1	Gain register	24 bits

**Table 11. Channel Selection for AD7705**

CH1	CH0	AIN(+)	AIN(-)	Calibration Register Pair
0	0	AIN1(+)	AIN1(-)	Register Pair 0
0	1	AIN2(+)	AIN2(-)	Register Pair 1
1	0	AIN1(-)	AIN1(-)	Register Pair 0
1	1	AIN1(-)	AIN2(-)	Register Pair 2

**Table 12. Channel Selection for AD7706**

CH1	CH0	AIN	Reference	Calibration Register Pair
0	0	AIN1	COMMON	Register Pair 0
0	1	AIN2	COMMON	Register Pair 1
1	0	COMMON	COMMON	Register Pair 0
1	1	AIN3	COMMON	Register Pair 2

## SETUP REGISTER (RS2, RS1, RS0 = 0, 0, 1); POWER-ON/RESET STATUS: 01 HEX

The setup register is an 8-bit register from which data can be read or to which data can be written. Table 13 outlines the bit designations for the setup register.

**Table 13. Setup Register**

MD1 (0)	MD0 (0)	G2 (0)	G1 (0)	G0 (0)	B/U (0)	BUF (0)	FSYNC (1)
---------	---------	--------	--------	--------	---------	---------	-----------

MD1, MD0 ADC Mode Bits. These bits select the operational mode of the ADC as outlined in Table 14.

G2–G0 Gain Selection Bits. These bits select the gain setting for the on-chip PGA, as outlined in Table 15.

$\overline{\text{B/U}}$  Bipolar/Unipolar Operation. A 0 in this bit selects bipolar operation; a 1 in this bit selects unipolar operation.

BUF Buffer Control. With this bit at 0, the on-chip buffer on the analog input is shorted out. With the buffer shorted out, the current flowing in the  $V_{DD}$  line is reduced. When this bit is high, the on-chip buffer is in series with the analog input, allowing the input to handle higher source impedances.

FSYNC Filter Synchronization. When this bit is high, the nodes of the digital filter, the filter control logic, the calibration control logic, and the analog modulator are held in a reset state. When this bit goes low, the modulator and filter start to process data, and a valid word is available in  $3 \times 1/(\text{output update rate})$ , i.e., the settling time of the filter. This FSYNC bit does not affect the digital interface and does not reset the  $\overline{\text{DRDY}}$  output if it is low.



Table 14. Operating Mode Options

MD1	MD0	Operating Mode
0	0	Normal Mode. In this mode, the device performs normal conversions.
0	1	Self-Calibration. This activates self-calibration on the channel selected by CH1 and CH0 of the communication register. This is a one-step calibration sequence. When the sequence is complete, the part returns to normal mode, with both MD1 and MD0 returning to 0. The DRDY output or bit goes high when calibration is initiated, and returns low when self-calibration is complete and a new valid word is available in the data register. The zero-scale calibration is performed at the selected gain on internally shorted (zeroed) inputs, and the full-scale calibration is performed at the selected gain on an internally generated $V_{REF}$ /selected gain.
1	0	Zero-Scale System Calibration. This activates zero-scale system calibration on the channel selected by CH1 and CH0 of the communication register. Calibration is performed at the selected gain on the input voltage provided at the analog input during this calibration sequence. This input voltage should remain stable for the duration of the calibration. The DRDY output or bit goes high when calibration is initiated, and returns low when zero-scale calibration is complete and a new valid word is available in the data register. At the end of the calibration, the part returns to normal mode, with both MD1 and MD0 returning to 0.
1	1	Full-Scale System Calibration. This activates full-scale system calibration on the selected input channel. Calibration is performed at the selected gain on the input voltage provided at the analog input during this calibration sequence. This input voltage should remain stable for the duration of the calibration. The DRDY output or bit goes high when calibration is initiated, and returns low when full-scale calibration is complete and a new valid word is available in the data register. At the end of the calibration, the part returns to normal mode, with both MD1 and MD0 returning to 0.

Table 15. Gain Selection

G2	G1	G0	Gain Setting
0	0	0	1
0	0	1	2
0	1	0	4
0	1	1	8
1	0	0	16
1	0	1	32
1	1	0	64
1	1	1	128

**CLOCK REGISTER (RS2, RS1, RS0 = 0, 1, 0); POWER-ON/RESET STATUS: 05 HEX**

The clock register is an 8-bit register from which data can be read or to which data can be written. Table 16 outlines the bit designations for the clock register.

Table 16. Clock Register

ZERO (0)	ZERO (0)	ZERO (0)	CLKDIS (0)	CLKDIV (0)	CLK (1)	FS1 (0)	FS0 (1)
----------	----------	----------	------------	------------	---------	---------	---------

**ZERO** Zero. A zero must be written to these bits to ensure correct operation of the AD7705/AD7706. Failure to do so might result in unspecified operation of the device.

**CLKDIS** Master Clock Disable Bit. Logic 1 in this bit disables the master clock, preventing it from appearing at the MCLK OUT pin. When disabled, the MCLK OUT pin is forced low. This feature allows the user the flexibility of either using the MCLK OUT as a clock source for other devices in the system, or turning off the MCLK OUT as a power-saving feature. When using an external master clock on the MCLK IN pin, the AD7705/AD7706 continue to have internal clocks and convert normally with the CLKDIS bit active. When using a crystal oscillator or ceramic resonator across the MCLK IN and MCLK OUT pins, the AD7705/AD7706 clocks are stopped, and no conversions take place when the CLKDIS bit is active.

**CLKDIV** Clock Divider Bit. With this bit at Logic 1, the clock frequency appearing at the MCLK IN pin is divided by 2 before being used internally by the AD7705/AD7706. For example, when this bit is set to Logic 1, the user can operate with a 4.9152 MHz crystal between MCLK IN and MCLK OUT, and internally the part operates with the specified 2.4576 MHz. With this bit at Logic 0, the clock frequency appearing at the MCLK IN pin is the frequency used internally by the part.

# AD7705/AD7706

**CLK** Clock Bit. This bit should be set in accordance with the operating frequency of the AD7705/AD7706. If the device has a master clock frequency of 2.4576 MHz (CLKDIV = 0) or 4.9152 MHz (CLKDIV = 1), this bit should be set to Logic 1. If the device has a master clock frequency of 1 MHz (CLKDIV = 0) or 2 MHz (CLKDIV = 1), this bit should be set to Logic 0. This bit sets up the appropriate scaling currents for a given operating frequency and, together with FS1 and FS0, chooses the output update rate for the device. If this bit is not set correctly for the master clock frequency of the device, the AD7705/AD7706 might not operate to specification.

**FS1, FS0** Filter Selection Bits. Along with the CLK bit, FS1 and FS0 determine the output update rate, the filter's first notch, and the -3 dB frequency, as outlined in Table 17. The on-chip digital filter provides a sinc<sup>3</sup> (or Sinx/x<sup>3</sup>) filter response. In association with the gain selection, it also determines the output noise of the device. Changing the filter notch frequency, as well as the selected gain, impacts resolution. Table 5 through Table 8 show the effects of filter notch frequency and gain on the output noise and effective resolution of the part. The output data rate, or effective conversion time, for the device is equal to the frequency selected for the first notch of the filter. For example, if the first notch of the filter is selected at 50 Hz, a new word is available at a 50 Hz output rate, or every 20 ms. If the first notch is at 500 Hz, a new word is available every 2 ms. A calibration should be initiated when any of these bits are changed. The settling time of the filter to a full-scale step input is worst case  $4 \times 1/(\text{output data rate})$ . For example, with the filter-first notch at 50 Hz, the settling time of the filter to a full-scale step input is 80 ms max. If the first notch is at 500 Hz, the settling time is 8 ms max. This settling time can be reduced to  $3 \times 1/(\text{output data rate})$  by synchronizing the step input change with a reset of the digital filter. In other words, if the step input takes place with the FSYNC bit high, the settling time is  $3 \times 1/(\text{output data rate})$  from the time when the FSYNC bit returns low. The -3 dB frequency is determined by the programmed first notch frequency according to the relationship:

$$\text{filter} - 3 \text{ dB frequency} = 0.262 \times \text{filter} - \text{first notch frequency}$$

**Table 17. Output Update Rates**

CLK <sup>1</sup>	FS1	FS0	Output Update Rate	-3 dB Filter Cutoff
0	0	0	20 Hz	5.24 Hz
0	0	1	25 Hz	6.55 Hz
0	1	0	100 Hz	26.2 Hz
0	1	1	200 Hz	52.4 Hz
1	0	0	50 Hz	13.1 Hz
1	0	1	60 Hz	15.7 Hz
1	1	0	250 Hz	65.5 Hz
1	1	1	500 Hz	131 Hz

<sup>1</sup> Assumes correct clock frequency on MCLK IN pin with the CLKDIV bit set appropriately.

## DATA REGISTER (RS2, RS1, RS0 = 0, 1, 1)

The data register is a 16-bit, read-only register that contains the most up-to-date conversion result from the AD7705/AD7706. If the communication register sets up the part for a write operation to this register, a write operation must take place to return the part to its default state. However, the 16 bits of data written to the part will be ignored by the AD7705/AD7706.

## TEST REGISTER (RS2, RS1, RS0 = 1, 0, 0); POWER-ON/RESET STATUS: 00 HEX

The part contains a test register that is used when testing the device. The user is advised not to change the status of any of the bits in this register from the default (power-on or reset) status of all 0s, because the part will be placed in one of its test modes and will not operate correctly.

**ZERO-SCALE CALIBRATION REGISTER (RS2, RS1, RS0 = 1, 1, 0); POWER-ON/RESET STATUS: 1F4000 HEX**

The AD7705/AD7706 contain independent sets of zero-scale registers, one for each of the input channels. Each register is a 24-bit read/write register; therefore, 24 bits of data must be written, or no data is transferred to the register. This register is used in conjunction with its associated full-scale register to form a register pair. These register pairs are associated with input channel pairs, as outlined in Table 11 and Table 12. While the part is set up to allow access to these registers over the digital interface, the parts themselves can no longer access the register coefficients to correctly scale the output data. As a result, the first output data read from the part after accessing the calibration registers (for either a read or write operation) might contain incorrect data. In addition, a write to the calibration register should not be attempted while a calibration is in progress. These eventualities can be avoided by taking the FSYNC bit in the mode register high before the calibration register operation, and taking it low after the operation is complete.

**FULL-SCALE CALIBRATION REGISTER (RS2, RS1, RS0 = 1, 1, 1); POWER-ON/RESET STATUS: 5761AB HEX**

The AD7705/AD7706 contain independent sets of full-scale registers, one for each of the input channels. Each register is a 24-bit read/write register; therefore, 24 bits of data must be written, or no data is transferred to the register. This register is used in conjunction with its associated zero-scale register to form a register pair. These register pairs are associated with input channel pairs, as outlined in Table 11 and Table 12. While the part is set up to allow access to these registers over the digital interface, the part itself can no longer access the register coefficients to correctly scale the output data. As a result, the first output data read from the part after accessing the calibration registers (for either a read or write operation) might contain incorrect data. In addition, a write to the calibration register should not be attempted while a calibration is in progress. These eventualities can be avoided by taking FSYNC bit in the mode register high before the calibration register operation, and taking it low after the operation is complete.

**Calibration Sequences**

The AD7705/AD7706 contain a number of calibration options, as previously outlined. Table 18 summarizes the calibration types, the operations involved, and the duration of the operations. There are two methods for determining the end of a calibration. The first is to monitor when  $\overline{\text{DRDY}}$  returns low at the end of the sequence. This technique not only indicates when the sequence is complete, but also when the part has a valid new sample in its data register. This valid new sample is the result of a normal conversion that follows the calibration sequence. The second method for determining when calibration is complete is to monitor the MD1 and MD0 bits of the setup register. When these bits return to 0 following a calibration command, the calibration sequence is complete. This technique can indicate the completion of a calibration earlier than the first method can, but it cannot indicate when there is a valid new result in the data register. The time that it takes the mode bits, MD1 and MD0, to return to 0 represents the duration of the calibration. The sequence when  $\overline{\text{DRDY}}$  goes low includes a normal conversion and a pipeline delay,  $t_p$ , to correctly scale the results of this first conversion. Note that  $t_p$  never exceeds  $2000 \times t_{\text{CLKIN}}$ . The time for both methods is shown in Table 18.

**Table 18. Calibration Sequences**

Calibration Type	MD1, MD0	Calibration Sequence	Duration of Mode Bits	Duration of $\overline{\text{DRDY}}$
Self-Calibration	0, 1	Internal ZS calibration @ selected gain + Internal FS calibration @ selected gain	$6 \times 1/\text{output rate}$	$9 \times 1/\text{output rate} + t_p$
ZS System Calibration	1, 0	ZS calibration on AIN @ selected gain	$3 \times 1/\text{output rate}$	$4 \times 1/\text{output rate} + t_p$
FS System Calibration	1, 1	FS calibration on AIN @ selected gain	$3 \times 1/\text{output rate}$	$4 \times 1/\text{output rate} + t_p$

## CIRCUIT DESCRIPTION

The AD7705/AD7706 are  $\Sigma$ - $\Delta$  analog-to-digital converters (ADC) with on-chip digital filtering, intended for the measurement of wide, dynamic range, low frequency signals, such as those in industrial-control or process-control applications. Each contains a  $\Sigma$ - $\Delta$  (or charge-balancing) ADC, a calibration microcontroller with on-chip static RAM, a clock oscillator, a digital filter, and a bidirectional serial communication port. The parts consume only 320  $\mu$ A of power supply current, making them ideal for battery-powered or loop-powered instruments. These parts operate with a supply voltage of 2.7 V to 3.3 V or 4.75 V to 5.25 V.

The AD7705 contains two programmable-gain, fully differential analog input channels, and the AD7706 contains three pseudo differential analog input channels. The selectable gains on these inputs are 1, 2, 4, 8, 16, 32, 64, and 128, allowing the parts to accept unipolar signals of 0 mV to 20 mV and 0 V to 2.5 V, or bipolar signals in the range of  $\pm 20$  mV to  $\pm 2.5$  V when the reference input voltage equals 2.5 V. With a reference voltage of 1.225 V, the input ranges are from 0 mV to 10 mV and 0 V to 1.225 V in unipolar mode, and from  $\pm 10$  mV to  $\pm 1.225$  V in bipolar mode. Note that the bipolar ranges are with respect to AIN(-) on the AD7705, and with respect to COMMON on the AD7706, but not with respect to GND.

The input signal to the analog input is continuously sampled at a rate determined by the frequency of the master clock, MCLK IN, and the selected gain. A charge-balancing ADC ( $\Sigma$ - $\Delta$  modulator)

converts the sampled signal into a digital pulse train whose duty cycle contains the digital information. The programmable gain function on the analog input is also incorporated in this  $\Sigma$ - $\Delta$  modulator, with the input sampling frequency being modified to provide higher gains. A sinc<sup>3</sup>, digital, low-pass filter processes the output of the  $\Sigma$ - $\Delta$  modulator and updates the output register at a rate determined by the first notch frequency of this filter. The output data can be read from the serial port randomly or periodically at any rate up to the output register update rate. The frequency of the first notch of the digital filter ranges from 50 Hz to 500 Hz; therefore, the programmable range for the -3 dB frequency is 13.1 Hz to 131 Hz. With a master clock frequency of 1 MHz, the programmable range for this first notch frequency is 20 Hz to 200 Hz, giving a programmable range for the -3 dB frequency of 5.24 Hz to 52.4 Hz.

The AD7705 Basic Connection Diagram is shown in Figure 13. It shows the AD7705 driven from an analog 5 V supply. An AD780 or REF192 precision 2.5 V reference provides the reference source for the part. On the digital side, the part is configured for 3-wire operation with  $\overline{\text{CS}}$  tied to GND. A quartz crystal or ceramic resonator provides the master clock source for the part. In most cases, it is necessary to connect capacitors on the crystal or resonator to ensure that it does not oscillate at overtones of its fundamental operating frequency. The values of capacitors vary, depending on the manufacturer's specifications. The same setup applies to the AD7706.

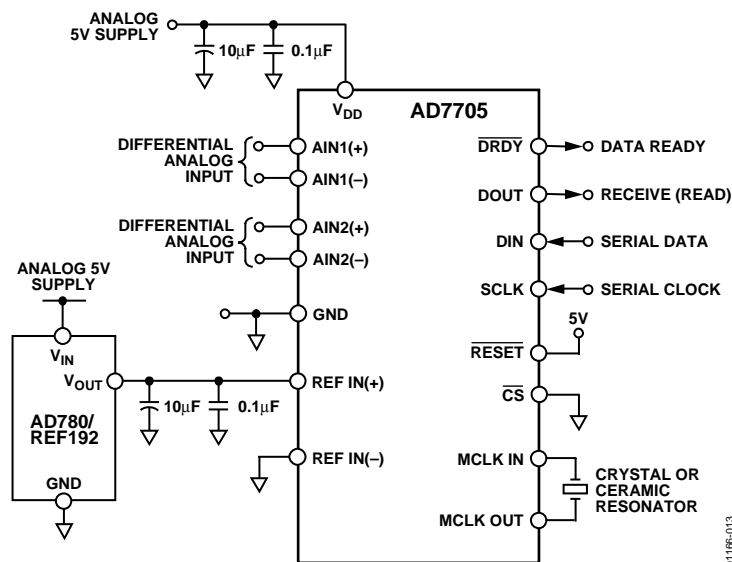

Figure 13. AD7705 Basic Connection Diagram

## ANALOG INPUT Ranges

The AD7705 contains two differential analog input pairs, AIN1(+)/AIN1(-) and AIN2(+)/AIN2(-). These input pairs provide programmable-gain, differential input channels that can handle either unipolar or bipolar input signals. It should be noted that the bipolar input signals are referenced to the respective AIN(-) input of each input pair. The AD7706 contains three pseudo differential analog input pairs, AIN1, AIN2, and AIN3, which are referenced to the COMMON input.

In unbuffered mode, the common-mode range of the input is from GND to  $V_{DD}$ , provided that the absolute value of the analog input voltage lies between  $GND - 100\text{ mV}$  and  $V_{DD} + 30\text{ mV}$ . Therefore, in unbuffered mode, the part can handle both unipolar and bipolar input ranges for all gains. The AD7705 can tolerate absolute analog input voltages down to  $GND - 200\text{ mV}$ , but the leakage current increases at high temperatures. In buffered mode, the analog inputs can handle much larger source impedances, but the absolute input voltage range is restricted to between  $GND + 50\text{ mV}$  and  $V_{DD} - 1.5\text{ V}$ , which also restricts the common-mode range. Therefore, in buffered mode, there are some restrictions on the allowable gains for bipolar input ranges. Care must be taken in setting up the common-mode voltage and input voltage ranges so that the above limits are not exceeded; otherwise, there is a degradation in linearity performance.

In unbuffered mode, the analog inputs look directly into the  $7\text{ pF}$  input sampling capacitor,  $C_{SAMP}$ . The dc input leakage current in this unbuffered mode is  $1\text{ nA}$  maximum. As a result, the analog inputs see a dynamic load that is switched at the input sample rate (see Figure 14). This sample rate depends on master clock frequency and selected gain.  $C_{SAMP}$  is charged to AIN(+) and discharged to AIN(-) every input sample cycle. The effective on resistance of the switch,  $R_{SW}$ , is typically  $7\text{ k}\Omega$ .

$C_{SAMP}$  must be charged through  $R_{SW}$  and any external source impedances every input sample cycle. Therefore, in unbuffered mode, source impedances mean a longer charge time for  $C_{SAMP}$ , which might result in gain errors on the parts. Table 19 shows the allowable external resistance-capacitance values for unbuffered mode, such that no gain error to the 16-bit level is introduced in the part. Note that these capacitances are total capacitances on the analog input—external capacitance plus  $10\text{ pF}$  capacitance from the pins and lead frame of the devices.

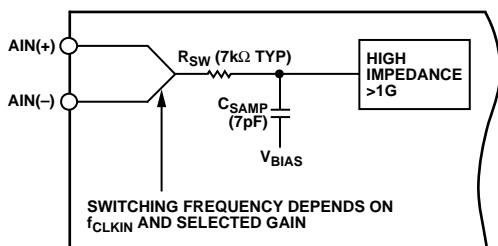

Figure 14. Unbuffered Analog Input Structure

Table 19. External Resistance-Capacitance Combination for Unbuffered Mode (Without 16-Bit Gain Error)

Gain	External Capacitance (pF)					
	10	50	100	500	1000	5000
1	152 k $\Omega$	53.9 k $\Omega$	31.4 k $\Omega$	8.4 k $\Omega$	4.76 k $\Omega$	1.36 k $\Omega$
2	75.1 k $\Omega$	26.6 k $\Omega$	15.4 k $\Omega$	4.14 k $\Omega$	2.36 k $\Omega$	670 $\Omega$
4	34.2 k $\Omega$	12.77 k $\Omega$	7.3 k $\Omega$	1.95 k $\Omega$	1.15 k $\Omega$	320 $\Omega$
8 to 128	16.7 k $\Omega$	5.95 k $\Omega$	3.46 k $\Omega$	924 $\Omega$	526 $\Omega$	150 $\Omega$

In buffered mode, the analog inputs look into the high impedance inputs stage of the on-chip buffer amplifier.  $C_{SAMP}$  is charged via this buffer amplifier such that source impedances do not affect the charging of  $C_{SAMP}$ . This buffer amplifier has an offset leakage current of  $1\text{ nA}$ . In this buffered mode, large source impedances result in a small dc offset voltage developed across the source impedance, but not in a gain error.

### Sample Rate

The modulator sample frequency for the AD7705/AD7706 remains at  $f_{CLKIN}/128$  ( $19.2\text{ kHz}$  @  $f_{CLKIN} = 2.4576\text{ MHz}$ ), regardless of the selected gain. However, gains greater than 1 are achieved by a combination of multiple input samples per modulator cycle and a scaling of the ratio of reference capacitor to input capacitor. As a result of the multiple sampling, the input sample rate of these devices varies with the selected gain (see Table 20). In buffered mode, the input is buffered before the input sampling capacitor. In unbuffered mode, where the analog input looks directly into the sampling capacitor, the effective input impedance is  $1/C_{SAMP} \times f_s$ , where  $C_{SAMP}$  is the input sampling capacitance and  $f_s$  is the input sample rate.

Table 20. Input Sampling Frequency vs. Gain

Gain	Input Sampling Frequency ( $f_s$ )
1	$f_{CLKIN}/64$ ( $38.4\text{ kHz}$ @ $f_{CLKIN} = 2.4576\text{ MHz}$ )
2	$2 \times f_{CLKIN}/64$ ( $76.8\text{ kHz}$ @ $f_{CLKIN} = 2.4576\text{ MHz}$ )
4	$4 \times f_{CLKIN}/64$ ( $76.8\text{ kHz}$ @ $f_{CLKIN} = 2.4576\text{ MHz}$ )
8 to 128	$8 \times f_{CLKIN}/64$ ( $307.2\text{ kHz}$ @ $f_{CLKIN} = 2.4576\text{ MHz}$ )

## BIPOLAR/UNIPOLAR INPUT

The analog inputs on the AD7705/AD7706 can accept either unipolar or bipolar input voltage ranges. Bipolar input ranges do not imply that these parts can handle negative voltages on their analog inputs; the analog inputs cannot go more negative than  $-100$  mV to ensure correct operation of these parts. The input channels are fully differential. As a result, on the AD7705, the voltage to which the unipolar and bipolar signals on the AIN(+) input are referenced is the voltage on the respective AIN(-) input. On the AD7706, the voltages applied to the analog input channels are referenced to the COMMON input. For example, if AIN1(-) is 2.5 V and AD7705 is configured for unipolar operation with a gain of 2 and a  $V_{REF}$  of 2.5 V, the input voltage range on the AIN1(+) input is 2.5 V to 3.75 V. If AIN1(-) is 2.5 V and AD7705 is configured for bipolar mode with a gain of 2 and a  $V_{REF}$  of 2.5 V, the analog input range on the AIN1(+) input is 1.25 V to 3.75 V (i.e.,  $2.5\text{ V} \pm 1.25\text{ V}$ ). If AIN1(-) is at GND, the part cannot be configured for bipolar ranges in excess of  $\pm 100$  mV.

Bipolar or unipolar options are chosen by programming the B/U bit of the setup register. This programs the channel for either unipolar or bipolar operation. Programming the channel for either unipolar or bipolar operation does not change the input signal conditioning, it simply changes the data output coding and the points on the transfer function where calibrations occur.

## REFERENCE INPUT

The AD7705/AD7706 reference inputs, REF IN(+) and REF IN(-), provide a differential reference input capability. The common-mode range for these differential inputs is from GND to  $V_{DD}$ . The nominal reference voltage,  $V_{REF}$  (REF IN(+) – REF IN(-)), for specified operation is 2.5 V for the AD7705/AD7706 operated with a  $V_{DD}$  of 5 V, and 1.225 V for the AD7705/AD7706 operated with a  $V_{DD}$  of 3 V. The parts are functional with  $V_{REF}$  voltages down to 1 V, but performance will be degraded because the output noise, in terms of LSB size, is larger. REF IN(+) must be greater than REF IN(-) for correct operation of the AD7705/AD7706.

Both reference inputs provide a high impedance, dynamic load similar to the analog inputs in unbuffered mode. The maximum dc input leakage current is  $\pm 1$  nA over temperature, and source resistance might result in gain errors on the part. In this case, the sampling switch resistance is 5 k $\Omega$  typ, and the reference capacitor,  $C_{REF}$ , varies with gain. The sample rate on the reference inputs is  $f_{CLKIN}/64$  and does not vary with gain. For gains of 1 and 2,  $C_{REF}$  is 8 pF; for gains of 16, 32, 64, and 128, it is 5.5 pF, 4.25 pF, 3.625 pF, and 3.3125 pF, respectively.

The output noise performance outlined in Table 5 through Table 8 is for an analog input of 0 V, which effectively removes the effect of noise on the reference. To obtain the noise performance shown in the noise tables over the full input range requires a low noise reference source for the AD7705/AD7706. If the

reference noise in the bandwidth of interest is excessive, it degrades the performance of the AD7705/AD7706. In applications where the excitation voltage for the bridge transducer on the analog input also derives the reference voltage for the part, the effect of the noise in the excitation voltage is removed because the application is ratiometric. Recommended reference voltage sources for the AD7705/AD7706 with a  $V_{DD}$  of 5 V include the AD780, REF43, and REF192; the recommended reference sources for the AD7705/AD7706 operated with a  $V_{DD}$  of 3 V include the AD589 and AD1580. It is generally recommended to decouple the output of these references to further reduce the noise level.

## DIGITAL FILTERING

The AD7705/AD7706 each contain an on-chip, low-pass digital filter that processes the output of the  $\Sigma$ - $\Delta$  modulator. Therefore, the parts not only provide the ADC function, but also provide a level of filtering. There are a number of system differences when the filtering function is provided in the digital domain, rather than in the analog domain.

For example, because it occurs after the A/D conversion process, digital filtering can remove noise injected during the conversion process, whereas analog filtering cannot do this. Also, the digital filter can be made programmable far more readily than can the analog filter. Depending on the digital filter design, this provides the user with the update rate.

On the other hand, analog filtering can remove noise superimposed on the analog signal before it reaches the ADC. Digital filtering cannot do this, and noise peaks riding on signals near full scale have the potential to saturate the analog modulator and digital filter, even though the average value of the signal is within limits. To alleviate this problem, the AD7705/AD7706 have overrange headroom built into the  $\Sigma$ - $\Delta$  modulator and digital filter that allows overrange excursions of 5% above the analog input range. If noise signals are larger than this, consider filtering the analog input, or reducing the input channel voltage so that its full scale is half that of the analog input channel full scale. This provides an overrange capability greater than 100% at the expense of reducing the dynamic range by 1 bit (50%).

In addition, the digital filter does not provide any rejection at integer multiples of the digital filter's sample frequency. However, the input sampling on the part provides attenuation at multiples of the digital filter's sampling frequency so that the unattenuated bands occur around multiples of the sampling frequency,  $f_s$ , as defined in Table 20. Thus, the unattenuated bands occur at  $n \times f_s$  (where  $n = 1, 2, 3 \dots$ ). At these frequencies, there are frequency bands  $\pm f_{3\text{dB}}$  wide ( $f_{3\text{dB}}$  is the cutoff frequency of the digital filter) at either side where noise passes unattenuated to the output.

### Filter Characteristics

The AD7705/AD7706 digital filter is a low-pass filter with a  $(\sin x/x)^3$  response (also called sinc<sup>3</sup>). The transfer function for the filter is described in the z-domain by

$$H(z) = \left| \frac{1}{N} \times \frac{1 - Z^{-N}}{1 - Z^{-1}} \right|^3$$

and in the frequency domain by

$$H(f) = \left| \frac{1}{N} \times \frac{\text{SIN}(N \times \pi \times f/f_s)}{\text{SIN}(\pi \times f/f_s)} \right|^3$$

where  $N$  is the ratio of the modulator rate to the output rate.

The phase response is defined by the following equation:

$$\angle H = -3\pi(N-2) \times f/f_s \text{ Rad}$$

Figure 15 shows the filter frequency response for a cutoff frequency of 15.72 Hz, which corresponds to a first filter notch frequency of 60 Hz. The plot is shown from dc to 390 Hz. This response is repeated at either side of the digital filter's sample frequency and at either side of multiples of the filter's sample frequency.

The response of the filter is similar to that of an averaging filter, but with a sharper roll-off. The output rate for the digital filter corresponds with the positioning of the first notch of the filter's frequency response. Thus, for Figure 15, where the output rate is 60 Hz, the first notch of the filter is at 60 Hz. The notches of this  $(\sin x/x)^3$  filter are repeated at multiples of the first notch. The filter provides attenuation of better than 100 dB at these notches.

The cutoff frequency of the digital filter is determined by the value loaded to Bit FS0 and Bit FS1 in the clock register. Programming a different cutoff frequency via Bit FS0 and Bit FS1 does not alter the profile of the filter response, but changes the frequency of the notches. The output update of the part and the frequency of the first notch correspond.

Because the AD7705/AD7706 contain this on-chip, low-pass filtering, a settling time is associated with step function inputs, and data on the output is invalid after a step change until the settling time has elapsed. The settling time depends on the output rate chosen for the filter. The settling time of the filter to a full-scale step input can be up to four times the output data period. For a synchronized step input using the FSYNC function, the settling time is three times the output data period.

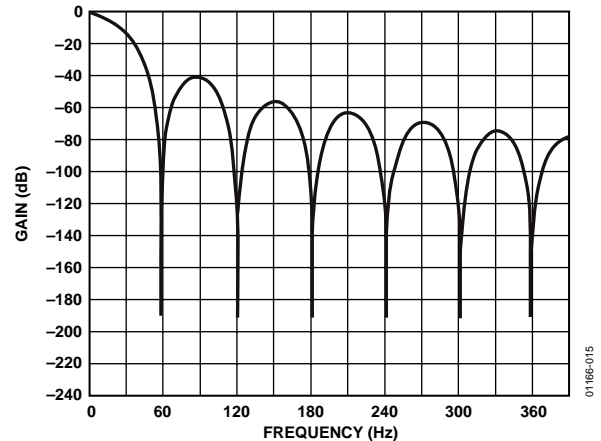

Figure 15. Frequency Response of AD7705 Filter

### Postfiltering

The on-chip modulator provides samples at a 19.2 kHz output rate with  $f_{\text{CLKIN}}$  at 2.4576 MHz. The on-chip digital filter decimates these samples to provide data at an output rate that corresponds to the programmed output rate of the filter. Because the output data rate is higher than the Nyquist criterion, the output rate for a given bandwidth satisfies most application requirements. There might, however, be some applications that require a higher data rate for a given bandwidth and noise performance. Applications that need this higher data rate will require postfiltering following the digital filtering performed by the AD7705/AD7706.

For example, if the required bandwidth is 7.86 Hz, but the required update rate is 100 Hz, data can be taken from the AD7705/AD7706 at the 100 Hz rate, giving a  $-3$  dB bandwidth of 26.2 Hz. Postfiltering can then be applied to reduce the bandwidth and output noise to the 7.86 Hz bandwidth level while maintaining an output rate of 100 Hz.

Postfiltering can also be used to reduce the output noise from the devices for bandwidths below 13.1 Hz. At a gain of 128 and a bandwidth of 13.1 Hz, the output rms noise is 450 nV. This is essentially device noise, or white noise. Because the input is chopped, the noise has a primarily flat frequency response. By reducing the bandwidth below 13.1 Hz, the noise in the resultant pass band is reduced. A reduction in bandwidth by a factor of 2 results in a reduction of approximately 1.25 in the output rms noise. This additional filtering results in a longer settling time.

## ANALOG FILTERING

The digital filter does not provide any rejection at integer multiples of the modulator sample frequency, as outlined earlier. However, due to the part's high oversampling ratio, these bands occupy only a small fraction of the spectrum, and most broadband noise is filtered. Therefore, the analog filtering requirements in front of the AD7705/AD7706 are considerably reduced vs. a conventional converter without on-chip filtering. In addition, because the parts' common-mode rejection performance of 100 dB extends to several kHz, common-mode noise in this frequency range is substantially reduced.

Depending on the application, however, it might be necessary to provide attenuation of the signal before it reaches the AD7705/AD7706 to eliminate unwanted frequencies that can pass through the digital filter. It might also be necessary to provide analog filtering in front of the AD7705/AD7706 to ensure that differential noise signals outside the band of interest do not saturate the analog modulator.

If passive components are placed in front of the AD7705/AD7706 in unbuffered mode, care must be taken to ensure that the source impedance is low enough not to introduce gain errors in the system. This significantly limits the amount of passive antialiasing filtering, which can be provided in front of the AD7705/AD7706 when the parts are used in unbuffered mode. However, when the parts are used in buffered mode, large source impedances result in a small dc offset error (a 10 k $\Omega$  source resistance causes an offset error of less than 10  $\mu$ V). Therefore, if the system requires significant source impedances to provide passive analog filtering in front of the AD7705/AD7706, it is recommended to operate the part in buffered mode.

## CALIBRATION

The AD7705/AD7706 provide a number of calibration options that can be programmed via the MD1 and MD0 bits of the setup register. The different calibration options are outlined in the Setup Register (RS2, RS1, RS0 = 0, 0, 1); Power-On/Reset Status: 01 Hex and Calibration Sequences sections. A calibration cycle can be initiated at any time by writing to these bits of the setup register. Calibration on the AD7705/AD7706 removes offset and gain errors from the devices. A calibration routine should be initiated on these devices whenever there is a change in the ambient operating temperature or supply voltage. It should also be initiated if there is a change in the selected gain, filter notch, or bipolar/unipolar input range.

The AD7705/AD7706 offer self-calibration and system calibration facilities. For full calibration to occur on the selected channel, the on-chip microcontroller must record the modulator output for two input conditions: zero-scale point and full-scale point. These points are derived by performing a conversion on the different input voltages provided to the input of the modulator during calibration. As a result, the accuracy of the calibration is only as good as the noise level that it provides in normal mode.

The result of the zero-scale calibration conversion is stored in the zero-scale calibration register, and the result of the full-scale calibration conversion is stored in the full-scale calibration register. With these readings, the microcontroller can calculate the offset and the gain slope for the input-to-output transfer function of the converter. Internally, the part works with a resolution of 33 bits to determine the conversion result of 16 bits.

### Self-Calibration

A self-calibration is initiated on the AD7705/AD7706 by writing the appropriate values (0, 1) to the MD1 and MD0 bits of the setup register. In self-calibration mode with a unipolar input range, the zero-scale point used to determine the calibration coefficients is with the inputs of the differential pair internally shorted on the part (i.e.,  $A_{IN}(+) = A_{IN}(-) =$  internal bias voltage on the AD7705, and  $A_{IN} = \text{COMMON} =$  internal bias voltage on the AD7706). The PGA is set for the selected gain for this zero-scale calibration conversion, as per the G1 and G0 bits in the communication register. The full-scale calibration conversion is performed at the selected gain on an internally generated voltage of  $V_{REF}/\text{selected gain}$ .

The duration time for the calibration is  $6 \times 1/\text{output rate}$ . This is composed of  $3 \times 1/\text{output rate}$  for the zero-scale calibration and  $3 \times 1/\text{output rate}$  for the full-scale calibration. Then, the MD1 and MD0 bits in the setup register return to 0, 0. This provides the earliest indication that the calibration sequence is complete. The  $\overline{\text{DRDY}}$  line goes high when calibration is initiated and does not return low until there is a valid new word in the data register. The duration time from the calibration command being issued to  $\overline{\text{DRDY}}$  going low is  $9 \times 1/\text{output rate}$ . This is composed of  $3 \times 1/\text{output rate}$  for the zero-scale calibration,  $3 \times 1/\text{output rate}$  for the full-scale calibration,  $3 \times 1/\text{output rate}$  for a conversion on the analog input, and some overhead to correctly set up the coefficients. If  $\overline{\text{DRDY}}$  is low before (or goes low during) writing the calibration command to the setup register, it can take up to one modulator cycle (MCLK IN/128) before  $\overline{\text{DRDY}}$  goes high to indicate that a calibration is in progress. Therefore,  $\overline{\text{DRDY}}$  should be ignored for one modulator cycle after the last bit is written to the setup register in the calibration command.

For bipolar input ranges in the self-calibrating mode, the sequence is very similar to that outlined in the previous paragraph. In this case, the two points are the same as above, but the shorted inputs point is midscale of the transfer function because the part is configured for bipolar operation.

### System Calibration

System calibration allows the AD7705/AD7706 to compensate for system gain and offset errors, as well as their own internal errors. System calibration performs the same slope factor calculations as self-calibration, but uses voltage values presented by the system to the AIN inputs for the zero- and full-scale points. Full system calibration requires a two-step process, a zero-scale system calibration followed by a full-scale system calibration.



For a full system calibration, the zero-scale point must be presented to the converter first. It must be applied to the converter before the calibration step is initiated and remain stable until the step is complete. Once the zero-scale voltage is set up, a zero-scale system calibration is initiated by writing the appropriate values (1, 0) to the MD1 and MD0 bits of the setup register. The zero-scale system calibration is performed at the selected gain. The duration of the calibration is  $3 \times 1/\text{output rate}$ . Then, the MD1 and MD0 bits in the setup register return to 0, 0, providing the earliest indication that the calibration sequence is complete. The  $\overline{\text{DRDY}}$  line goes high when calibration is initiated and returns low when there is a valid new word in the data register. The duration time from the calibration command being issued to  $\overline{\text{DRDY}}$  going low is  $4 \times 1/\text{output rate}$ , because the part performs a normal conversion on the AIN voltage before  $\overline{\text{DRDY}}$  goes low. If  $\overline{\text{DRDY}}$  is low before (or goes low during) writing the calibration command to the setup register, it can take up to one modulator cycle (MCLK IN/128) before  $\overline{\text{DRDY}}$  goes high to indicate that a calibration is in progress. Therefore,  $\overline{\text{DRDY}}$  should be ignored for one modulator cycle after the last bit is written to the setup register in the calibration command.

After the zero-scale point is calibrated, the full-scale point is applied to AIN, and the second step of the calibration process is initiated by writing the appropriate values (1, 1) to MD1 and MD0. The full-scale voltage must be set up before the calibration is initiated and remain stable throughout the calibration step. The full-scale system calibration is performed at the selected gain. The duration of the calibration is  $3 \times 1/\text{output rate}$ . Then, the MD1 and MD0 bits in the setup register return to 0, 0, providing the earliest indication that the calibration sequence is complete. The  $\overline{\text{DRDY}}$  line goes high when calibration is initiated and returns low when there is a valid new word in the data register. The duration time from the calibration command being issued to  $\overline{\text{DRDY}}$  going low is  $4 \times 1/\text{output rate}$ , because the part performs a normal conversion on the AIN voltage before  $\overline{\text{DRDY}}$  goes low. If  $\overline{\text{DRDY}}$  is low before (or goes low during) writing the calibration command to the setup register, it can take up to one modulator cycle (MCLK IN/128) before  $\overline{\text{DRDY}}$  goes high to indicate that calibration is in progress. Therefore,  $\overline{\text{DRDY}}$  should be ignored for one modulator cycle after the last bit is written to the setup register in the calibration command.

In unipolar mode, the system calibration is performed between the two endpoints of the transfer function. In bipolar mode, it is performed between midscale (zero differential voltage) and positive full scale.

The fact that the system calibration involves two steps offers another feature. After the sequence of a full system calibration is complete, additional offset or gain calibrations can be performed individually to adjust the system zero reference point or the system gain. Calibrating one of the parameters, either system offset or system gain, does not affect the other parameter.

When the part is used in unbuffered mode, system calibration can be used to remove errors from source impedances on the analog input. A simple R-C antialiasing filter on the front end can introduce a gain error on the analog input voltage, but the system calibration can be used to remove this error.

### **Span and Offset Limits**

Whenever the system calibration mode is used, there are limits on the amount of offset and span that can be accommodated. The overriding requirement for determining the amount of offset and gain that can be accommodated by the part is that the positive full-scale calibration limit is  $< 1.05 \times V_{\text{REF}}/\text{GAIN}$ . This allows the input range to go 5% above the nominal range. The built-in headroom in the AD7705/AD7706 analog modulator ensures that the parts operate correctly with a positive full-scale voltage that is 5% beyond the nominal.

The range of input span in both the unipolar and bipolar modes has a minimum value of  $0.8 \times V_{\text{REF}}/\text{GAIN}$  and a maximum value of  $2.1 \times V_{\text{REF}}/\text{GAIN}$ . However, when determining the span, which is the difference between the bottom and top of the devices' input range, the user must take into account the limitation on the positive full-scale voltage. The amount of offset that can be accommodated depends on whether the unipolar or bipolar mode is used, and the user must also take into account the limitation on the positive full-scale voltage. In unipolar mode, there is considerable flexibility in handling negative offsets with respect to AIN(–) on the AD7705, and with respect to COMMON on the AD7706. In both unipolar and bipolar modes, the range of positive offsets that can be handled by the part depends on the selected span. Therefore, in determining the limits for system zero-scale and full-scale calibrations, the user must ensure that the offset range plus the span range does not exceed  $1.05 \times V_{\text{REF}}/\text{GAIN}$ . This is best illustrated by looking at a few examples.

If the part is used in unipolar mode with a required span of  $0.8 \times V_{\text{REF}}/\text{GAIN}$ , the offset range that the system calibration can handle is  $-1.05 \times V_{\text{REF}}/\text{GAIN}$  to  $+0.25 \times V_{\text{REF}}/\text{GAIN}$ . If the part is used in unipolar mode with a required span of  $V_{\text{REF}}/\text{GAIN}$ , the offset range that the system calibration can handle is  $-1.05 \times V_{\text{REF}}/\text{GAIN}$  to  $+0.05 \times V_{\text{REF}}/\text{GAIN}$ . Similarly, if the part is used in unipolar mode and required to remove an offset of  $0.2 \times V_{\text{REF}}/\text{GAIN}$ , the maximum span range that the system calibration can handle is  $0.85 \times V_{\text{REF}}/\text{GAIN}$ .

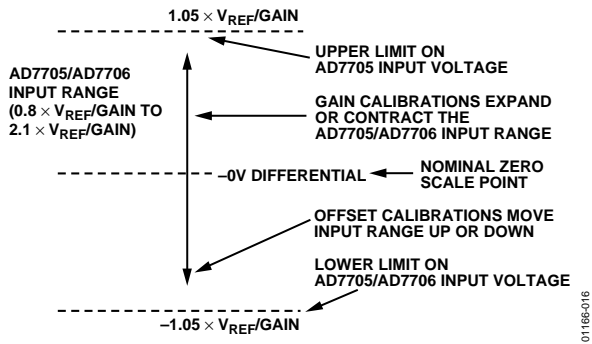

Figure 16. Span and Offset Limits

If the part is used in bipolar mode with a required span of  $\pm 0.4 \times V_{REF}/GAIN$ , the offset range that the system calibration can handle is  $-0.65 \times V_{REF}/GAIN$  to  $+0.65 \times V_{REF}/GAIN$ . If the part is used in bipolar mode with a required span of  $\pm V_{REF}/GAIN$ , the offset range that the system calibration can handle is  $-0.05 \times V_{REF}/GAIN$  to  $+0.05 \times V_{REF}/GAIN$ . Similarly, if the part is used in bipolar mode and required to remove an offset of  $\pm 0.2 \times V_{REF}/GAIN$ , the maximum span range that the system calibration can handle is  $\pm 0.85 \times V_{REF}/GAIN$ .

## Power-Up and Calibration

Upon power-up, the AD7705/AD7706 internally reset, setting the contents of the internal registers to a known state. Default values are loaded to all registers after a power-on or reset. The default values contain nominal calibration coefficients for the calibration registers. However, to ensure correct calibration for the devices, a calibration routine should be performed after power-up.

The power dissipation and temperature drift of the AD7705/AD7706 are low, and no warm-up time is required before the initial calibration is performed. However, if an external reference is used, it must be stabilized before calibration is initiated. Similarly, if the clock source for the part is generated from a crystal or resonator across the MCLK pins, the start-up time for the oscillator circuit should elapse before a calibration is initiated on the parts (see Figure 11).

## THEORY OF OPERATION

### CLOCKING AND OSCILLATOR CIRCUIT

The AD7705/AD7706 each require a master clock input, which can be an external CMOS-compatible clock signal applied to the MCLK IN pin with the MCLK OUT pin left unconnected. Alternatively, a crystal or ceramic resonator of the correct frequency can be connected between MCLK IN and MCLK OUT, as shown in Figure 17. In this case, the clock circuit functions as an oscillator, providing the clock source for the part. The input sampling frequency, modulator sampling frequency,  $-3$  dB frequency, output update rate, and calibration time are directly related to the master clock frequency,  $f_{CLKIN}$ . Reducing the master clock frequency by a factor of 2 halves the above frequencies and update rate and doubles the calibration time. The current drawn from the  $V_{DD}$  power supply is also related to  $f_{CLKIN}$ . Reducing  $f_{CLKIN}$  by a factor of 2 halves the digital part of the total  $V_{DD}$  current, but does not affect the current drawn by the analog circuitry.

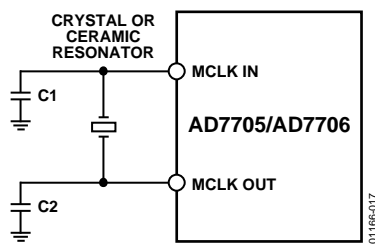

Figure 17. Crystal/Resonator Connection for the AD7705/AD7706

Using the part with a crystal or ceramic resonator between the MCLK IN and MCLK OUT pins generally causes more current to be drawn from  $V_{DD}$  than does clocking the part from a driven clock signal at the MCLK IN pin. This is because the on-chip oscillator circuit is active in the case of the crystal or ceramic resonator. Therefore, the lowest possible current on the AD7705/AD7706 is achieved with an externally applied clock at the MCLK IN pin with MCLK OUT unconnected, unloaded, and disabled.

The amount of additional current taken by the oscillator depends on a number of factors. For example, the larger the value of the capacitor (C1 and C2) placed on the MCLK IN and MCLK OUT pins, the larger the current consumption on the AD7705/AD7706. Care should be taken not to exceed the capacitor values recommended by the crystal and ceramic resonator manufacturers to avoid unnecessarily consuming current. Typical values for C1 and C2 are recommended by crystal or ceramic resonator manufacturers, usually in the range of 30 pF to 50 pF. If the capacitor values on MCLK IN and MCLK OUT are kept in this range, they do not result in any excessive current. Another factor that influences the current is the effective series resistance (ESR) of the crystal that appears between the MCLK IN and MCLK OUT pins of the AD7705/AD7706. As a general rule, the lower the ESR value, the lower the current taken by the oscillator circuit.

When operating with a clock frequency of 2.4576 MHz, there is 50  $\mu$ A difference in the current between an externally applied clock and a crystal resonator operated with a  $V_{DD}$  of 3 V. With  $V_{DD} = 5$  V and  $f_{CLKIN} = 2.4576$  MHz, the typical current increases by 250  $\mu$ A for a crystal- or resonator-supplied clock vs. an externally applied clock. The ESR values for crystals and resonators at this frequency tend to be low, and, as a result, there tends to be little difference between different crystal and resonator types.

When operating with a clock frequency of 1 MHz, the ESR value for different crystal types varies significantly. As a result, the current drain varies across crystal types. When using a crystal with an ESR of 700  $\Omega$ , or when using a ceramic resonator, the increase in the typical current over an externally applied clock is 20  $\mu$ A with  $V_{DD} = 3$  V, and 200  $\mu$ A with  $V_{DD} = 5$  V. When using a crystal with an ESR of 3 k $\Omega$ , the increase in the typical current over an externally applied clock is 100  $\mu$ A with  $V_{DD} = 3$  V, but 400  $\mu$ A with  $V_{DD} = 5$  V.

There is a start-up time before the on-chip oscillator circuit oscillates at its correct frequency and voltage levels. Typical start-up times with  $V_{DD} = 5$  V are 6 ms using a 4.9512 MHz crystal, 16 ms with a 2.4576 MHz crystal, and 20 ms with a 1 MHz crystal oscillator. Start-up times are typically 20% slower when a 3 V power supply is used. With 3 V supplies, depending on the loading capacitances on the MCLK pins, a 1 M $\Omega$  feedback resistor might be required across the crystal or resonator to keep the start-up times around 20 ms.

The AD7705/AD7706 master clock appears on the MCLK OUT pin of the device. The maximum recommended load on this pin is 1 CMOS load. When using a crystal or ceramic resonator to generate the AD7705/AD7706 clock, it might be desirable to use this clock as the clock source for the system. In this case, it is recommended that the MCLK OUT signal is buffered with a CMOS buffer before being applied to the rest of the circuit.

### SYSTEM SYNCHRONIZATION

The FSYNC bit of the setup register allows the user to reset the modulator and digital filter without affecting the setup conditions on the part. This allows the user to start gathering samples of the analog input at a known point in time, i.e., when the FSYNC is changed from 1 to 0.

With a 1 in the FSYNC bit of the setup register, the digital filter and analog modulator are held in a known reset state, and the part does not process input samples. When a 0 is written to the FSYNC bit, the modulator and filter are taken out of this reset state, and the part resumes gathering samples on the next master clock edge.

## AD7705/AD7706

The FSYNC input can also be used as a software start convert command, allowing the AD7705/AD7706 to be operated in a conventional converter fashion. In this mode, writing to the FSYNC bit starts conversion, and the falling edge of  $\overline{\text{DRDY}}$  indicates when conversion is complete. The disadvantage of this scheme is that the settling time of the filter must be taken into account for every data register update; therefore, the rate at which the data register is updated is three times slower in this mode.

Because the FSYNC bit resets the digital filter, the full settling time of  $3 \times 1/\text{output rate}$  must elapse before a new word is loaded to the output register. If the  $\overline{\text{DRDY}}$  signal is low when FSYNC goes to 0, the  $\overline{\text{DRDY}}$  signal is not reset to high by the FSYNC command, because the AD7705/AD7706 recognize that there is a word in the data register that has not been read. The  $\overline{\text{DRDY}}$  line stays low until an update of the data register takes place, at which time it goes high for  $500 \times t_{\text{CLKIN}}$  before returning low again. A read from the data register resets the  $\overline{\text{DRDY}}$  signal high, and it does not return low until the settling time of the filter has elapsed and there is a valid new word in the data register. If the  $\overline{\text{DRDY}}$  line is high when the FSYNC command is issued, the  $\overline{\text{DRDY}}$  line does not return low until the settling time of the filter has elapsed.

### RESET INPUT

The RESET input on the AD7705/AD7706 resets the logic, digital filter, analog modulator, and on-chip registers to their default states.  $\overline{\text{DRDY}}$  is driven high, and the AD7705/AD7706 ignore all communication to their registers while the RESET input is low. When the RESET input returns high, the AD7705/AD7706 start to process data, and  $\overline{\text{DRDY}}$  returns low in  $3 \times 1/\text{output rate}$ , indicating a valid new word in the data register. However, the AD7705/AD7706 operate with their default setup conditions after a reset, and it is generally necessary to set up all registers and perform a calibration after a RESET command.

The AD7705/AD7706 on-chip oscillator circuit continues to function even when the RESET input is low, and the master clock signal continues to be available on the MCLK OUT pin. Therefore, in applications where the system clock is provided by the AD7705/AD7706 clock, the AD7705/AD7706 produce an uninterrupted master clock during a RESET command.

### STANDBY MODE

The STBY bit in the communication register of the AD7705/AD7706 allows the user to place the part in a power-down mode when it is not required to provide conversion results. The AD7705/AD7706 retain the contents of their on-chip registers, including the data register, while in standby mode. When released from standby mode, the parts start to process data, and a new word is available in the data register in  $3 \times 1/\text{output rate}$  from when a 0 is written to the STBY bit.

The STBY bit does not affect the digital interface, nor does it affect the status of the  $\overline{\text{DRDY}}$  line. If  $\overline{\text{DRDY}}$  is high when the STBY bit is brought low, it remains high until there is a valid new word in the data register. If  $\overline{\text{DRDY}}$  is low when the STBY bit is brought low, it remains low until the data register is updated, at which time the  $\overline{\text{DRDY}}$  line returns high for  $500 \times t_{\text{CLKIN}}$  before returning low again. If  $\overline{\text{DRDY}}$  is low when the part enters standby mode, indicating a valid unread word in the data register, the data register can be read while the part is in standby. At the end of this read operation,  $\overline{\text{DRDY}}$  is reset to high.

Placing the part in standby mode reduces the total current to 9  $\mu\text{A}$  typical with  $V_{\text{DD}} = 5 \text{ V}$ , and 4  $\mu\text{A}$  with  $V_{\text{DD}} = 3 \text{ V}$  when the part is operated from an external master clock, provided that this master clock has stopped. If the external clock continues to run in standby mode, the standby current increases to 150  $\mu\text{A}$  typical with 5 V supplies, and 75  $\mu\text{A}$  typical with 3.3 V supplies. If a crystal or ceramic resonator is used as the clock source, the total current in standby mode is 400  $\mu\text{A}$  typical with 5 V supplies, and 90  $\mu\text{A}$  with 3.3 V supplies. This is because the on-chip oscillator circuit continues to run when the part is in standby mode. This is important in applications where the system clock is provided by the AD7705/AD7706 clock so that the AD7705/AD7706 produce an uninterrupted master clock in standby mode.

### ACCURACY

$\Sigma\text{-}\Delta$  ADCs, like VFCs and other integrating ADCs, do not contain a source of nonmonotonicity and inherently offer no missing codes performance. The AD7705/AD7706 achieve excellent linearity by using high quality, on-chip capacitors that have a very low capacitance/voltage coefficient. The devices also achieve low input drift by using chopper-stabilization techniques in their input stage. To ensure excellent performance over time and temperature, the AD7705/AD7706 use digital calibration techniques that minimize offset and gain error.

### DRIFT CONSIDERATIONS

The AD7705/AD7706 use chopper-stabilization techniques to minimize input offset drift. Charge injection in the analog switches and dc-leakage currents at the sampling node are the primary sources of offset voltage drift in the converter. The dc input leakage current is essentially independent of the selected gain. Gain drift within the converter primarily depends on the temperature tracking of the internal capacitors. It is not affected by leakage currents.

Measurement errors due to offset drift or gain drift can be eliminated at any time by recalibrating the converter. Using the system calibration mode also minimizes offset and gain errors in the signal conditioning circuitry. Integral and differential linearity errors are not significantly affected by temperature changes.

## POWER SUPPLIES

The AD7705/AD7706 operate with  $V_{DD}$  power supplies between 2.7 V and 5.25 V. Although the latch-up performance of the AD7705/AD7706 is good, it is important that power is applied to the AD7705/AD7706 before signals are applied at the REF IN, AIN, or logic input pins to avoid excessive currents. If this is not possible, the current through these pins should be limited. If separate supplies are used for the AD7705/AD7706 and the system digital circuitry, the AD7705/AD7706 should be powered up first. If it is not possible to guarantee this, current-limiting resistors should be placed in series with the logic inputs to limit the current. The latch-up current is greater than 100 mA.

## SUPPLY CURRENT

The current consumption on the AD7705/AD7706 is specified for supplies in the range of 2.7 V to 3.3 V and 4.75 V to 5.25 V. The parts operate over a 2.7 V to 5.25 V supply range, and the  $I_{DD}$  changes as the supply voltage varies over this range. There is an internal current boost bit on the AD7705/AD7706 that is set internally in accordance with the operating conditions. This affects the current drawn by the analog circuitry within these devices. Minimum power consumption is achieved when the AD7705/AD7706 are operated with an  $f_{CLKIN}$  of 1 MHz, or at gains of 1 to 4 with  $f_{CLKIN} = 2.4575$  MHz, because the internal boost bit reduces the analog current consumption. Figure 18 shows the variation of the typical  $I_{DD}$  with  $V_{DD}$  voltage for both a 1 MHz crystal oscillator and a 2.4576 MHz crystal oscillator at 25°C. The AD7705/AD7706 are operated in unbuffered mode. The relationship shows that the  $I_{DD}$  is minimized by operating the part with lower  $V_{DD}$  voltages.  $I_{DD}$  on the AD7705/AD7706 is also minimized by using an external master clock, or by optimizing external components when using the on-chip oscillator circuit. Figure 6, Figure 7, Figure 9, and Figure 10 show variations in  $I_{DD}$  with gain,  $V_{DD}$ , and clock frequency using an external clock.

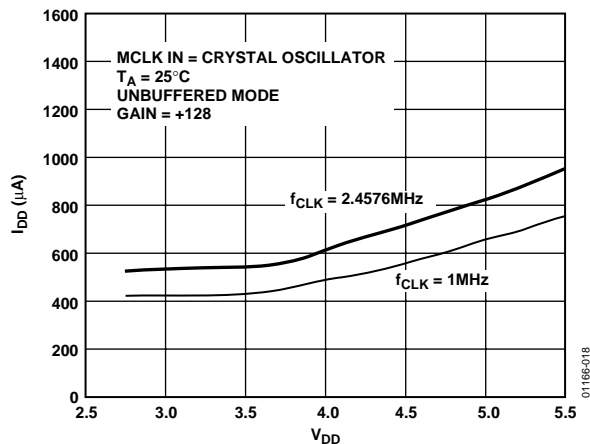

Figure 18.  $I_{DD}$  vs. Supply Voltage

## GROUNDING AND LAYOUT

Because the analog inputs and reference input are differential, most of the voltages in the analog modulator are common-mode voltages. The excellent common-mode rejection of the parts removes common-mode noise on these inputs. The digital filter provides rejection of broadband noise on the power supplies, except at integer multiples of the modulator sampling frequency. The digital filter also removes noise from the analog and reference inputs, provided that those noise sources do not saturate the analog modulator. As a result, the AD7705/AD7706 are more immune to noise interference than conventional high resolution converters. However, because the resolutions of the AD7705/AD7706 are so high and the noise levels from the AD7705/AD7706 are so low, care must be taken with regard to grounding and layout.

The printed circuit board that houses the AD7705/AD7706 should be designed so that the analog and digital sections are separated and confined to certain areas of the board. This facilitates the use of ground planes that can be separated easily. A minimum etch technique is generally best for ground planes, because it provides the best shielding. Digital and analog ground planes should only be joined in one place to avoid ground loops. If the AD7705/AD7706 are in a system where multiple devices require AGND-to-DGND connections, the AGND-to-DGND connection should only be made at one point, a star ground point, which should be established as close as possible to the AD7705/AD7706 GND.

Avoid running digital lines under the device, because they couple noise onto the die. The analog ground plane should be allowed to run under the AD7705/AD7706 to avoid noise coupling. The power supply lines to the AD7705/AD7706 should use as large a trace as possible to provide low impedance paths and reduce the effects of glitches on the power supply line. Fast switching signals, such as clock signals, should be shielded with digital ground to avoid radiating noise to other sections of the board, and clock signals should never be run near the analog inputs. Avoid crossover of digital and analog signals. Traces on opposite sides of the board should run at right angles to each other. This reduces the effects of feedthrough through the board. Using a microstrip technique works best, but it is not always possible to use this method with a double-sided board. In this technique, the component side of the board is dedicated to ground planes, and signals are placed on the solder side.

Good decoupling is important when using high resolution ADCs. All analog supplies should be decoupled with 10  $\mu$ F tantalum in parallel with 0.1  $\mu$ F ceramic capacitors to GND. To achieve the best from these decoupling components, place them as close as possible to the device, ideally right up against the device. All logic chips should be decoupled with 0.1  $\mu$ F disc ceramic capacitors to DGND.

## EVALUATING THE PERFORMANCE

The recommended layout for the AD7705/AD7706 is outlined in their associated evaluations. Each evaluation board package includes a fully assembled and tested evaluation board, documentation, software for controlling the board over the printer port of a PC, and software for analyzing its performance on a PC.

Noise levels in the signals applied to the AD7705/AD7706 can also affect performance of the parts. The AD7705/AD7706 software evaluation packages allow the user to evaluate the true performance of the parts independently of the analog input signals. For the AD7705, the scheme involves using a test mode with the inputs internally shorted together to provide a zero differential voltage for the analog modulator. External to the AD7705, the AIN1(–) input should be connected to a voltage that is within the allowable common-mode range of the part. Similarly, on the AD7706 for evaluation purposes, the COMMON input should be connected to a voltage within its allowable common-mode range. This scheme should be used after a calibration is performed on the parts.

## DIGITAL INTERFACE

As previously outlined, the AD7705/AD7706 programmable functions are controlled using a set of on-chip registers. Data is written to these registers via the serial interface, which also provides read access to the on-chip registers. All communication to the parts must start with a write operation to the communication register. After a power-on or reset, the devices expect a write to their communication registers. The data written to these registers determine whether the next operation is a read or write operation and to which register this operation occurs. Therefore, write access to a register on either part starts with a write operation to the communication register, followed by a write to the selected register. Likewise, a read operation from any register, including the output data register, starts with a write operation to the communication register, followed by a read operation from the selected register.

The AD7705/AD7706 serial interfaces each consist of five signals:  $\overline{CS}$ , SCLK, DIN, DOUT, and  $\overline{DRDY}$ . The DIN line is used for transferring data into the on-chip registers, and the DOUT line is used for accessing data from the on-chip registers. SCLK is the serial clock input for the device, and all data transfers on either DIN or DOUT take place with respect to this SCLK signal. The  $\overline{DRDY}$  line is used as a status signal to indicate when data is ready to be read from the AD7705/AD7706 data registers.  $\overline{DRDY}$  goes low when a new data-word is available in the output register. It is reset high when a read operation from the data register is complete. It also goes high prior to updating the output register, indicating not to read from the device, to ensure that a data read is not attempted while the register is updated.  $\overline{CS}$  is used to select the device. It can be used to decode the AD7705/AD7706 in systems where a number of parts are connected to the serial bus.

Figure 19 and Figure 20 show timing diagrams for interfacing to the AD7705/AD7706, with  $\overline{CS}$  used to decode the parts. Figure 19 shows a read operation from the AD7705/AD7706 output shift register, and Figure 20 shows a write operation to the input shift register. It is possible to read the same data twice from the output register, even though the  $\overline{DRDY}$  line returns high after the first read operation. Care must be taken, however, to ensure that the read operation is complete before the next output update takes place.

The AD7705/AD7706 serial interface can operate in 3-wire mode by tying the  $\overline{CS}$  input low. In this case, the SCLK, DIN, and DOUT lines are used to communicate with the AD7705/AD7706, and the status of  $\overline{DRDY}$  can be obtained by interrogating the MSB of the communication register. This scheme is suitable for interfacing to microcontrollers. If  $\overline{CS}$  is required as a decoding signal, it can be generated from a port bit. For microcontroller interfaces, it is recommended that the SCLK idles high between data transfers.

The AD7705/AD7706 can also be operated with  $\overline{CS}$  used as a frame synchronization signal. This scheme is suitable for DSP interfaces. In this case, the first bit (MSB) is effectively clocked out by  $\overline{CS}$ , because  $\overline{CS}$  normally occurs after the falling edge of SCLK in DSP interfaces. The SCLK can continue to run between data transfers, provided that the timing numbers are obeyed.

The serial interface can be reset by exercising the  $\overline{RESET}$  input. It can also be reset by writing a series of 1s on the DIN input. If Logic 1 is written to the AD7705/AD7706 DIN line for at least 32 serial clock cycles, the serial interface is reset. This ensures that in 3-wire systems, if the interface is lost via either a software error or a glitch in the system, it can be reset to a known state. This state returns the interface to where the AD7705/AD7706 are expecting a write operation to their communication registers. This operation in itself does not reset the contents of any registers, but it is advisable to set up all registers again, because the information written to the registers is unknown due to the interface being lost.

Some microprocessor or microcontroller serial interfaces have a single serial data line. In this case, it is possible to connect the AD7705/AD7706 DATA OUT and DATA IN lines together and connect them to the single data line of the processor. A 10 k $\Omega$  pull-up resistor should be used on this single data line. In this case, if the interface is lost, the procedure to reset it back to a known state is somewhat different than previously described because the read and write operations share the same line. Instead, a read operation of 24 serial clocks is required, followed by a write operation where Logic 1 is written for at least 32 serial clock cycles to ensure that the serial interface resets to a known state.

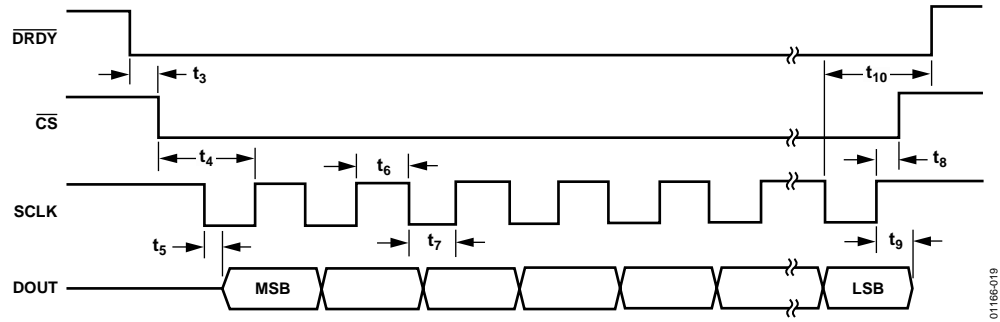

Figure 19. Read Cycle Timing Diagram

01166-019

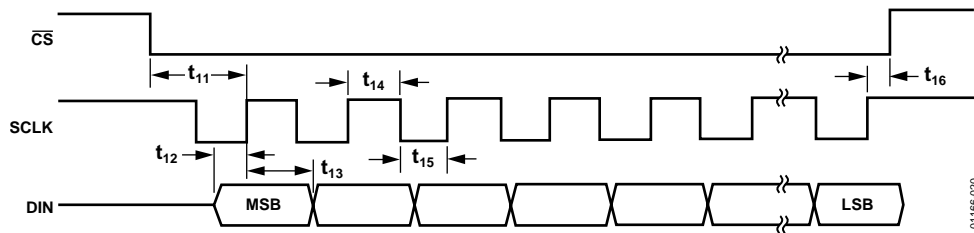

Figure 20. Write Cycle Timing Diagram

01166-020

# AD7705/AD7706

## CONFIGURING THE AD7705/AD7706

The AD7705/AD7706 contain six on-chip registers that the user can access via the serial interface. Communication with any of these registers is initiated by first writing to the communication register. Figure 21 outlines a flowchart of the sequence used to configure registers after a power-up or reset on the AD7705; similar procedures apply to the AD7706. The flowchart also

shows two read options—one polls the  $\overline{\text{DRDY}}$  pin, and the other interrogates the DRDY pin. In addition, Figure 21 shows a series of words that should be written to the registers for the following operating conditions: Gain 1, no filter sync, bipolar mode, buffer off, clock of 4.9512 MHz, and output rate of 50 Hz.

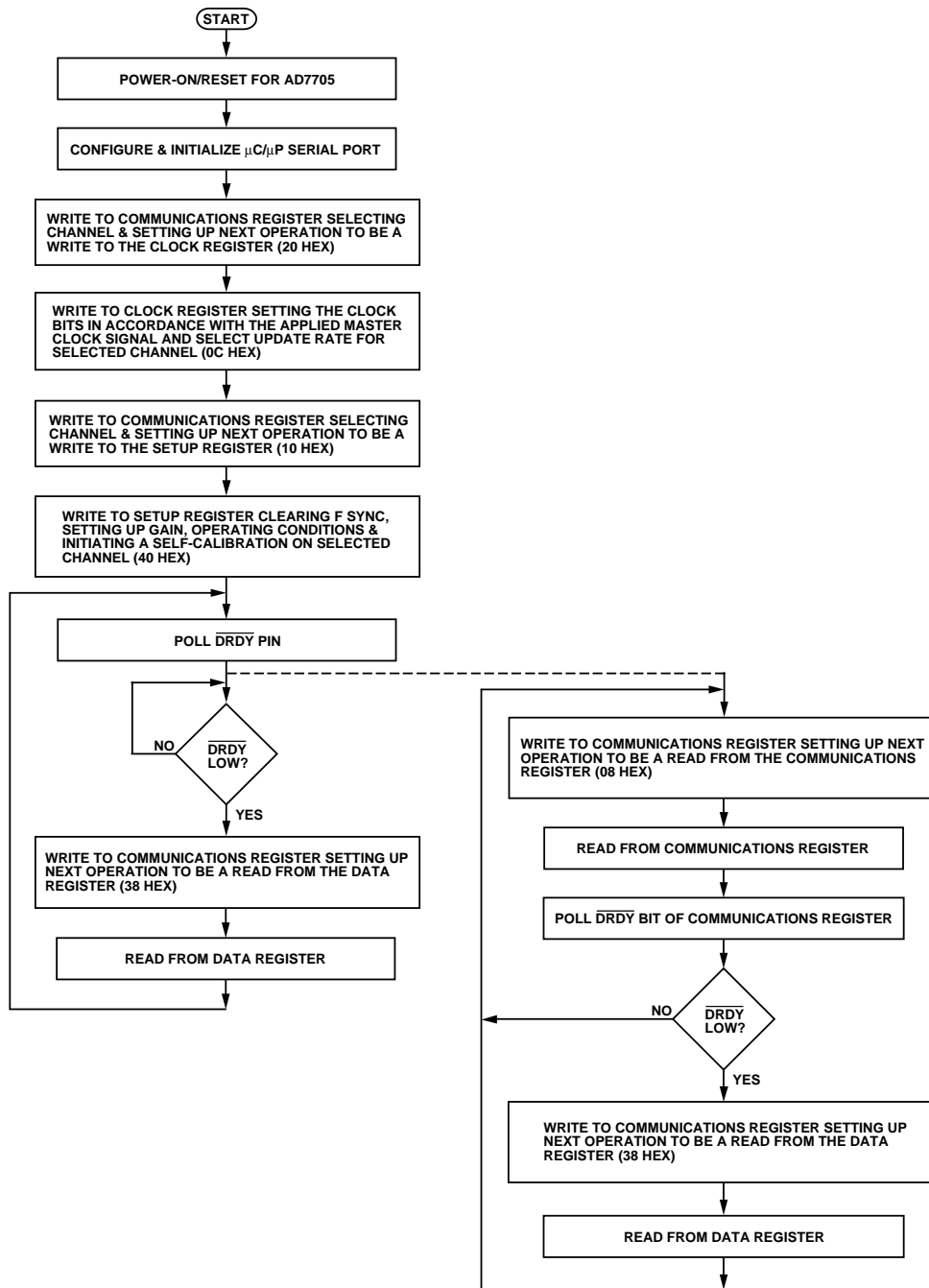

Figure 21. Flowchart for Setting Up and Reading from the AD7705



## MICROCOMPUTER/MICROPROCESSOR INTERFACING

The flexible serial interface of the AD7705/AD7706 allows easy interfacing to most microcomputers and microprocessors. The flowchart in Figure 21 outlines the sequence to follow when interfacing a microcontroller or microprocessor to the AD7705/AD7706. Figure 22 through Figure 24 show typical interface circuits.

The serial interface is capable of operating from three wires and is compatible with SPI interface protocols. The 3-wire operation makes these parts ideal for an isolated system in which minimizing the number of interface lines minimizes the number of opto-isolators required in the system. The serial clock input is a Schmitt-triggered input to accommodate slow edges from opto-couplers. The rise and fall times of other digital inputs to the AD7705/AD7706 should be no longer than 1  $\mu$ s.

Most of the registers on the AD7705/AD7706 are 8-bit registers, which facilitates easy interfacing to the 8-bit serial ports of microcontrollers. The data register on the AD7705/AD7706 is 16 bits, and the offset and gain registers are 24-bit registers, but data transfers to these registers can consist of multiple 8-bit transfers to the serial port of the microcontroller. DSP processors and microprocessors generally transfer 16 bits of data in a serial data operation. Some of these processors, such as the ADSP-2105, have the facility to program the number of cycles in a serial transfer. This allows the user to tailor the number of bits in any transfer to match the length of the required register in the AD7705/AD7706.

Because some registers on the AD7705/AD7706 are only 8 bits long, successive write operations to two of these registers can be handled as a single 16-bit data transfer. For example, to update the setup register, the processor must write to the communication register to indicate that the next operation is a write to the setup register, and then write 8 bits to the setup register. This can be done in a single 16-bit transfer, because once the eight serial clocks of the write operation to the communication register are complete, the part immediately sets up for a write operation to the setup register.

### AD7705/AD7706-to-68HC11 Interface

Figure 22 shows an interface between the AD7705/AD7706 and the 68HC11 microcontroller. The diagram shows the minimum (3-wire) interface with  $\overline{CS}$  on the AD7705/AD7706 hardwired low. In this scheme, the  $\overline{DRDY}$  bit of the communication register is monitored to determine when the data register is updated. An alternative scheme, which increases the number of interface lines to four, is to monitor the  $\overline{DRDY}$  output line from the AD7705/AD7706. Monitoring the  $\overline{DRDY}$  line can be done in two ways. First,  $\overline{DRDY}$  can be connected to a 68HC11 port bit (such as PC0) that is configured as an input. This port bit is then polled to determine the status of  $\overline{DRDY}$ . The second scheme is to use an interrupt-driven system, in which case the  $\overline{DRDY}$  output is connected to the  $\overline{IRQ}$  input of the 68HC11. For interfaces that require control of the  $\overline{CS}$  input on the AD7705/AD7706, a port bit of the 68HC11 (such as PC1) that is configured as an output can be used to drive the  $\overline{CS}$  input.

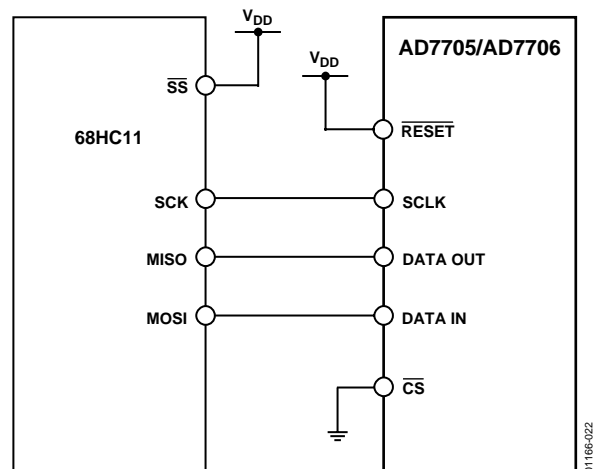

Figure 22. AD7705/AD7706-to-68HC11 Interface

The 68HC11 is configured in master mode with its CPOL and CPHA bits set to Logic 1. When the 68HC11 is configured like this, its SCLK line idles high between data transfers. The AD7705/AD7706 are not capable of a full duplex operation. If the AD7705/AD7706 are configured for a write operation, no data appears on the DATA OUT lines, even when the SCLK input is active. Similarly, if the AD7705/AD7706 are configured for a read operation, data presented to the part on the DATA IN line is ignored, even when SCLK is active.

Coding for an interface between the 68HC11 and the AD7705/AD7706 is given in the C Code for Interfacing AD7705 to 68HC11 section. In this example, the  $\overline{DRDY}$  output line of the AD7705 is connected to the PC0 port bit of the 68HC11 and is polled to determine its status.

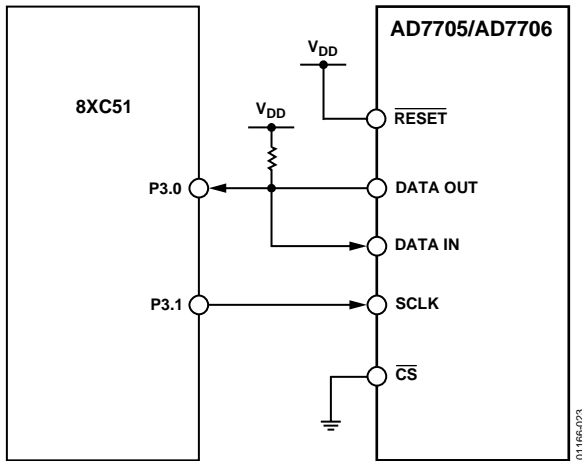

Figure 23. AD7705/AD7706-to-8XC51 Interface

## AD7705/AD7706-to-8051 Interface

An interface circuit between the AD7705/AD7706 and the 8XC51 microcontroller is shown in Figure 23. The diagram shows the minimum number of interface connections with  $\overline{CS}$  on the AD7705/AD7706 hardwired low. In the case of the 8XC51 interface, the minimum number of interconnects is two. In this scheme, the  $\overline{DRDY}$  bit of the communication register is monitored to determine when the data register is updated. The alternative scheme, which increases the number of interface lines to three, is to monitor the  $\overline{DRDY}$  output line from the AD7705/AD7706. Monitoring the  $\overline{DRDY}$  line can be done in two ways. First,  $\overline{DRDY}$  can be connected to a 8XC51 port bit (such as P1.0) that is configured as an input. This port bit is then polled to determine the status of  $\overline{DRDY}$ . The second scheme is to use an interrupt-driven system, in which case the  $\overline{DRDY}$  output is connected to the  $\overline{INT1}$  input of the 8XC51. For interfaces that require control of the  $\overline{CS}$  input on the AD7705/AD7706, a port bit of the 8XC51 (such as P1.1) that is configured as an output can be used to drive the  $\overline{CS}$  input. The 8XC51 is configured in Mode 0 serial interface mode. Its serial interface contains a single data line. As a result, the DATA OUT and DATA IN pins of the AD7705/AD7706 should be connected together with a 10 kΩ pull-up resistor. The serial clock on the 8XC51 idles high between data transfers. During a write operation, the 8XC51 outputs the LSB first. Because the AD7705/AD7706 expect the MSB first, the data must be rearranged before being written to the output serial register. Similarly, during a read operation, the AD7705/AD7706 output the MSB first, and the 8XC51 expects the LSB first. Therefore, the data read into the serial buffer must be rearranged before the correct data word from the AD7705/AD7706 is available in the accumulator.

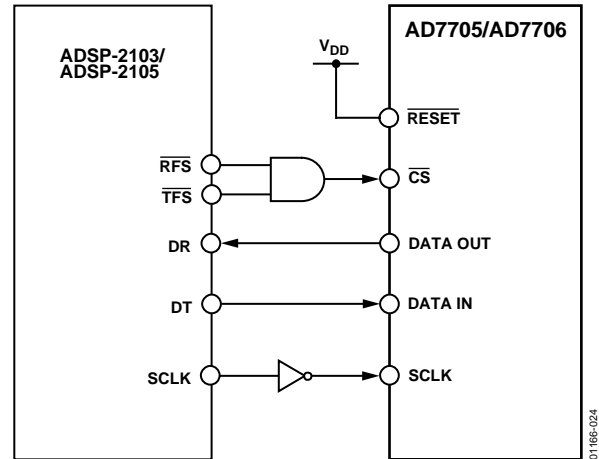

Figure 24. AD7705/AD7706-to-ADSP-2103/ADSP-2105 Interface

## AD7705/AD7706-to-ADSP-2103/ADSP-2105 Interface

Figure 24 shows an interface between the AD7705/AD7706 and the ADSP-2103/ADSP-2105 DSP processor. In the interface shown, the  $\overline{DRDY}$  bit of the communication register is monitored to determine when the data register is updated. The alternative scheme is to use an interrupt-driven system, in which case the  $\overline{DRDY}$  output is connected to the  $\overline{IRQ2}$  input of the ADSP-2103/ADSP-2105. The serial interface of the ADSP-2103/ADSP-2105 is set up for alternate framing mode. The  $\overline{RFS}$  and  $\overline{TFS}$  pins of the ADSP-2103/ADSP-2105 are configured as active low outputs, and the ADSP-2103/ADSP-2105 serial clock line, SCLK, is configured as an output. The  $\overline{CS}$  for the AD7705/AD7706 is active when either the  $\overline{RFS}$  or  $\overline{TFS}$  outputs from the ADSP-2103/ADSP-2105 are active. The serial clock rate on the ADSP-2103/ADSP-2105 should be limited to 3 MHz to ensure correct operation with the AD7705/AD7706.

### CODE FOR SETTING UP THE AD7705/AD7706

The following section shows a set of read and write routines in C code for interfacing the 68HC11 microcontroller to the AD7705. The sample program sets up the various registers on the AD7705 and reads 1000 samples from one channel into the 68HC11. The setup conditions on the part are the same as those outlined for the flowchart of Figure 21. In the example code given here, the  $\overline{\text{DRDY}}$  output is polled to determine if a new valid word is available in the data register. The same sequence is applicable for the AD7706.

The sequence of events in this program are as follows:

1. Write to the communication register, selecting Channel 1 as the active channel and setting the next operation to be a write to the clock register.
2. Write to clock register, setting the CLKDIV bit, which divides the external clock internally by two. This assumes that the external crystal is 4.9512 MHz. The update rate is selected to be 50 Hz.
3. Write to Communication Register selecting Channel 1 as the active channel and setting the next operation to be a write to the Setup Register.
4. Write to the Setup Register, setting the gain to 1, setting bipolar mode, buffer off, clearing the filter synchronization and initiating a self-calibration.
5. Poll the  $\overline{\text{DRDY}}$  output.
6. Read the data from the Data Register.
7. Loop around doing Steps 5 and 6 until the specified number of samples has been taken from the selected channel.

# AD7705/AD7706

## **C Code for Interfacing AD7705 to 68HC11**

```
#include <math.h>

#include <io6811.h>

#define NUM_SAMPLES 1000 /* change the number of data samples */
#define MAX_REG_LENGTH 2 /* this says that the max length of a register is 2 bytes */

Writetoreg (int);
Read (int,char);
char *datapointer = store;
char store[NUM_SAMPLES*MAX_REG_LENGTH + 30];

void main()
{
    /* the only pin that is programmed here from the 68HC11 is the /CS and this is why the PC2 bit of PORTC is made as
an output */
    char a;
    DDRC = 0x04; /* PC2 is an output the rest of the port bits are inputs */
    PORTC |= 0x04; /* make the /CS line high */
    Writetoreg(0x20); /* Active Channel is Ain1(+)/Ain1(-), next operation as write to the clock register */
    Writetoreg(0x0C); /* master clock enabled, 4.9512MHz Clock, set output rate to 50Hz*/
    Writetoreg(0x10); /* Active Channel is Ain1(+)/Ain1(-), next operation as write to the setup register */
    Writetoreg(0x40); /* gain = 1, bipolar mode, buffer off, clear FSYNC and perform a Self Calibration*/
    while(PORTC & 0x10); /* wait for /DRDY to go low */
    for(a=0;a<NUM_SAMPLES;a++){
        {
            Writetoreg(0x38); /*set the next operation for 16 bit read from the data register */
            Read(NUM_SAMPES,2);
        }
    }
    Writetoreg(int byteword);
    {
        int q;
        SPCR = 0x3f;
        SPCR = 0X7f; /* this sets the WiredOR mode(DWOM=1), Master mode(MSTR=1), SCK idles high(CPOL=1), /SS can be low
always (CPHA=1), lowest clock speed(slowest speed which is master clock /32 */
```

```

DDRD = 0x18; /* SCK, MOSI outputs */
q = SPDR;

q = SPDR; /* the read of the status register and of the data register is needed to clear the interrupt which tells the user that the
data transfer is complete */

PORTC &= 0xfb; /* /CS is low */

SPDR = byteward; /* put the byte into data register */

while(!(SPSR & 0x80)); /* wait for /DRDY to go low */

PORTC |= 0x4; /* /CS high */
}

Read(int amount, int reglength)
{
int q;
SPCR = 0x3f;

SPCR = 0x7f; /* clear the interrupt */

DDRD = 0x10; /* MOSI output, MISO input, SCK output */

while(PORTC & 0x10); /* wait for /DRDY to go low */

PORTC & 0xfb ; /* /CS is low */

for(b=0;b<reglength;b++)
    {
        SPDR = 0;

        while(!(SPSR & 0x80)); /* wait until port ready before reading */

        *datapointer++=SPDR; /* read SPDR into store array via datapointer */
    }

PORTC|=4; /* /CS is high */
}

```

## APPLICATIONS

The AD7705 provides a dual-channel, low cost, high resolution analog-to-digital function. Because the analog-to-digital function is provided by a  $\Sigma$ - $\Delta$  architecture, the part is more immune to noisy environments, thus making it ideal for use in industrial and process-control applications. It also provides a programmable gain amplifier, digital filter, and calibration options. Therefore, it provides far more system level functionality than off-the-shelf integrating ADCs, but without the disadvantage of needing to supply a high quality integrating capacitor. In addition, using the AD7705 in a system allows the designer to achieve a much higher level of resolution, because noise performance of the AD7705 is better than that of the integrating ADCs.

The on-chip PGA allows the AD7705 to handle an analog input voltage range as low as 10 mV full scale with  $V_{REF} = 1.25$  V. The differential inputs of the part allow the absolute value of this analog input range to be between GND and  $V_{DD}$  when the part is operated in unbuffered mode. It allows the user to connect the transducer directly to the input of the AD7705. The programmable-gain front end on the AD7705 allows the part to handle unipolar analog input ranges from (0 mV to 20 mV) to (0 V to 2.5 V), and bipolar inputs of  $\pm 20$  mV to  $\pm 2.5$  V. Because the part operates from a single supply, these bipolar ranges are with respect to a biased-up differential input.

## PRESSURE MEASUREMENT

One typical application of the AD7705 is pressure measurement. Figure 25 shows the AD7705 used with a pressure transducer, the BP01 from SenSym. The pressure transducer is arranged in a bridge network and provides a differential output voltage between its OUT(+) and OUT(-) terminals. With rated, full-scale pressure (in this case 300 mmHg) on the transducer, the differential output voltage is 3 mV/V of the input voltage (that is, the voltage between its IN(+) and IN(-) terminals). Assuming a 5 V excitation voltage, the full-scale output from the transducer is 15 mV. The excitation voltage for the bridge is also used to generate the reference voltage for the AD7705. Therefore, variations in the excitation voltage do not introduce errors in the system. Choosing resistor values of 24 k $\Omega$  and 15 k $\Omega$ , as per Figure 25, results in a 1.92 V reference voltage for the AD7705 when the excitation voltage is 5 V.

Using the part with a programmed gain of 128 results in the full-scale input span of the AD7705 being 15 mV, which corresponds with the output span from the transducer. The second channel on the AD7705 can be used as an auxiliary channel to measure a secondary variable, such as temperature, as shown in Figure 25. This secondary channel can be used as a means of adjusting the output of the primary channel, thus removing temperature effects in the system.

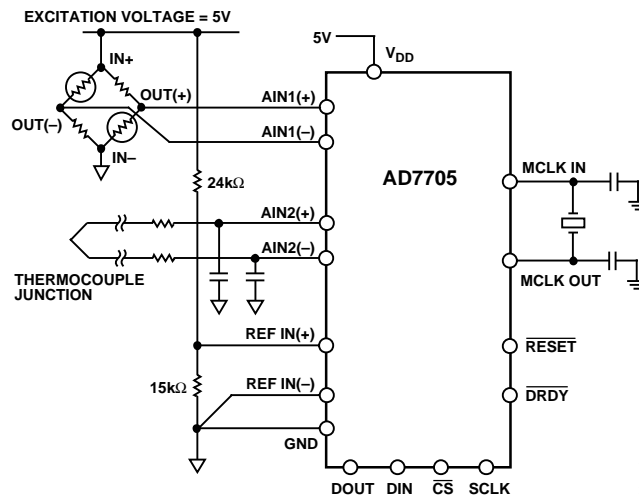

Figure 25. Pressure Measurement Using the AD7705

## TEMPERATURE MEASUREMENT

Another application of the AD7705 is temperature measurement. Figure 26 outlines a connection between a thermocouple and the AD7705. For this application, the AD7705 is operated in buffered mode to allow large decoupling capacitors on the front end to eliminate any noise pickup from the thermocouple leads. When the AD7705 is operated in buffered mode, it has a reduced common-mode range. To place the differential voltage from the thermocouple on a suitable common-mode voltage, the AIN1(-) input of the AD7705 is biased up at the reference voltage, 2.5 V.

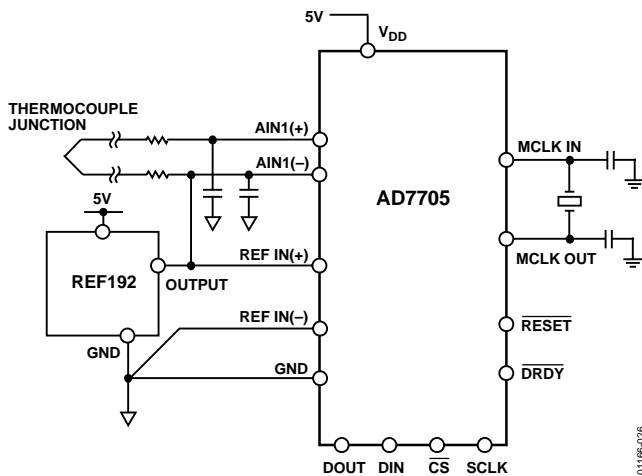

Figure 26. Temperature Measurement Using the AD7705

Figure 27 shows another example of a temperature measurement application for the AD7705. In this case, the transducer is a resistive temperature device (RTD), a PT100, and the arrangement is a 4-lead RTD configuration. There are voltage drops across lead resistances  $R_{L1}$  and  $R_{L4}$ , which shift the common-mode voltage. There is no voltage drop across lead resistances  $R_{L2}$  and  $R_{L3}$ , because the input current to the

AD7705 is very low. The lead resistances present a small source impedance; therefore, it is not generally necessary to use the buffer of the AD7705. If the buffer is required, the common-mode voltage should be set accordingly by inserting a small resistance between the bottom end of the RTD and the GND of the AD7705. In the application shown, an external 400  $\mu$ A current source provides the excitation current for the PT100 and generates the reference voltage for the AD7705 via the 6.25 k $\Omega$  resistor. Variations in the excitation current do not affect the circuit, because both the input voltage and the reference voltage vary radiometrically with the excitation current. However, the 6.25 k $\Omega$  resistor must have a low temperature coefficient to avoid errors in the reference voltage over temperature.

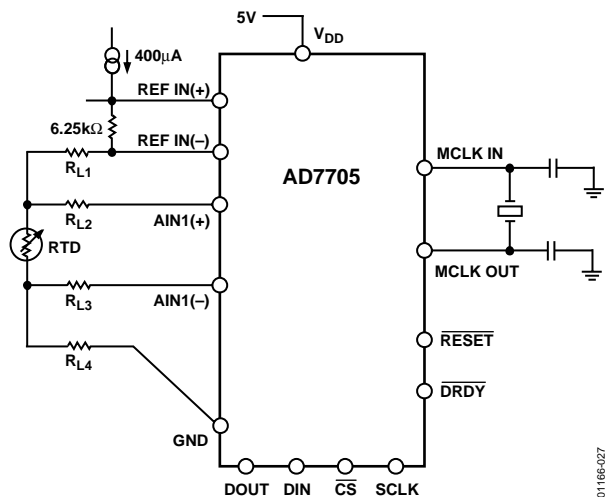

Figure 27. RTD Measurement Using the AD7705

# AD7705/AD7706

## SMART TRANSMITTERS

Another application where the low power, single supply, 3-wire interface capabilities of the AD7705/AD7706 are of benefit is in smart transmitters. Figure 28 shows a block diagram of a smart transmitter using the AD7705. Because a smart transmitter must operate from a 4 mA to 20 mA loop, tolerances in the loop

mean that the current available to power the transmitter can be as low as 3.5 mA. The AD7705 consumes only 320  $\mu$ A, leaving at least 3 mA available for the rest of the transmitter. The AD7705, with its dual-input channel, is ideally suited for systems requiring an auxiliary channel whose measured variable is used to correct that of the primary channel.

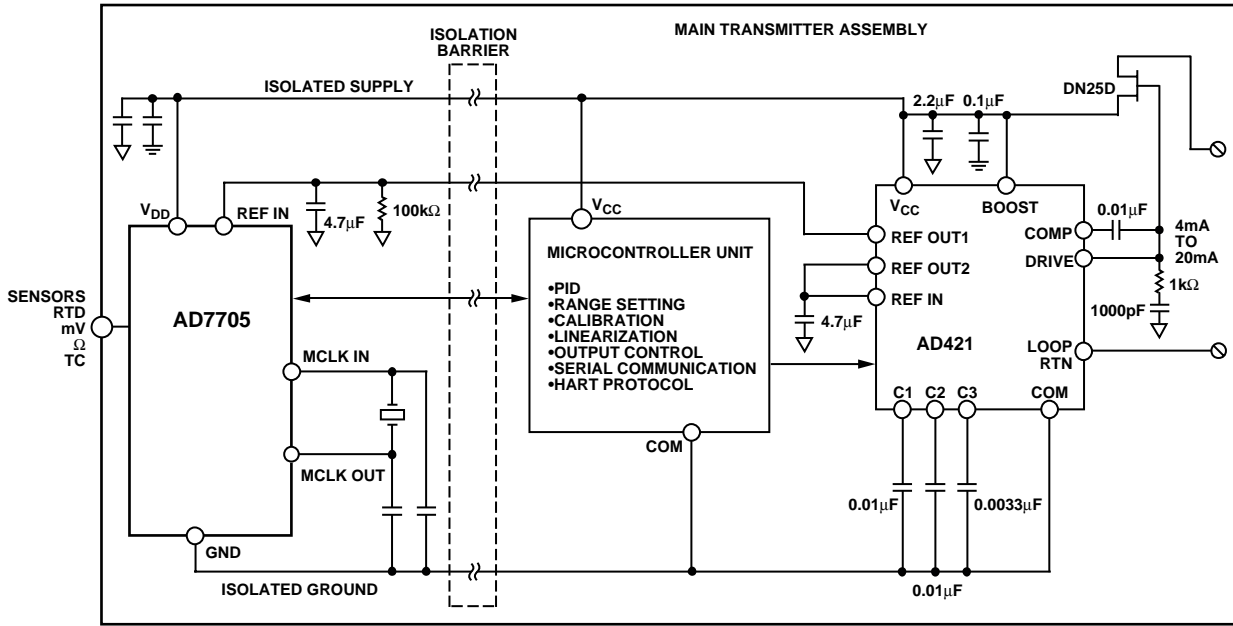

Figure 28. Smart Transmitter Using the AD7705



## BATTERY MONITORING

An application where the low power, single supply operation is required is battery monitoring in portable equipment applications. Figure 29 shows a block diagram of a battery monitor using the AD7705 and an external multiplexer to differentially measure the voltage across a single cell. The second channel on the AD7705 is used to monitor current drain from the battery. The AD7705, with its dual-input channel, is ideally suited for measurement systems requiring two input channels, as in this case, to monitor voltage and current. Because the AD7705 can accommodate very low input signals,  $R_{SENSE}$  can be kept low, reducing

undesired power dissipation. Operating with a gain of 128, a  $\pm 9.57$  mV full-scale signal can be measured with a resolution of  $2 \mu\text{V}$ , giving 13.5 bits of flicker-free performance in such a system. To obtain specified performance in unbuffered mode, the common-mode range of the input is GND to  $V_{DD}$ , provided that the absolute value of the analog input voltage lies between  $\text{GND} - 100$  mV and  $V_{DD} + 30$  mV. Absolute voltages of  $\text{GND} - 200$  mV can be accommodated on the AD7705 at  $25^\circ\text{C}$  without any degradation in performance, but with significantly increased leakage at elevated temperatures.

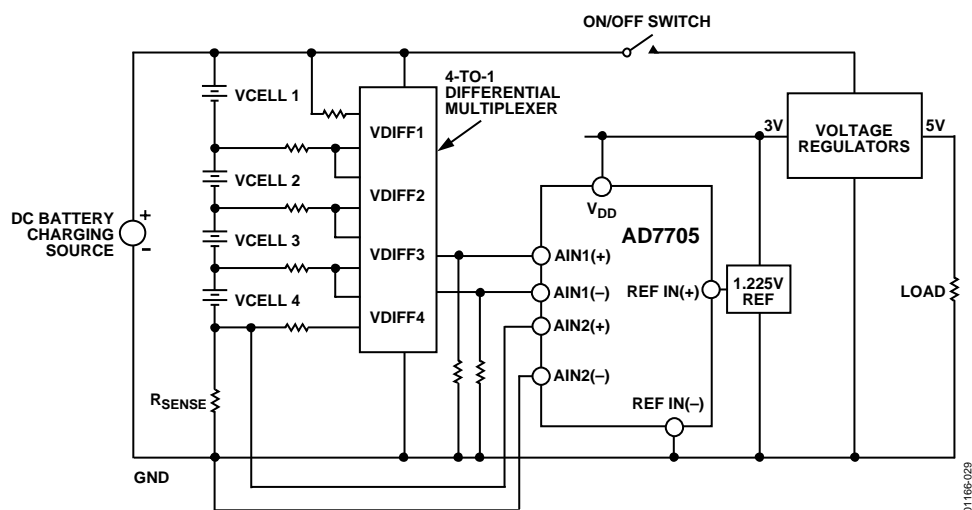

Figure 29. Battery Monitoring Using the AD7705

OUTLINE DIMENSIONS

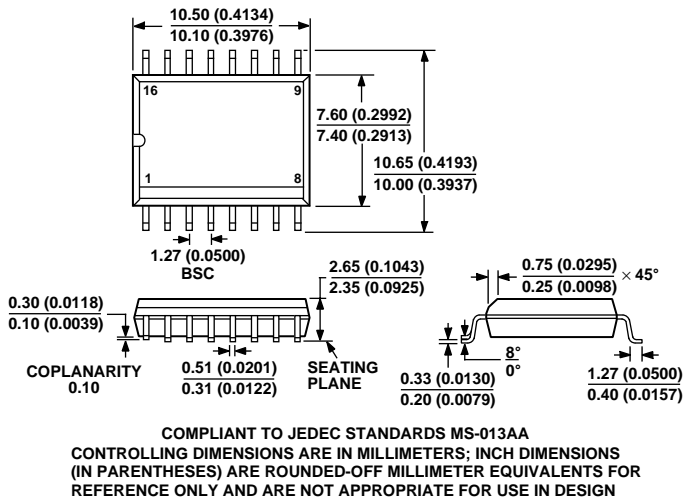

Figure 30. 16-Lead Standard Small Outline Package [SOIC]  
Wide Body  
(R-16)  
Dimensions shown in millimeters and (inches)

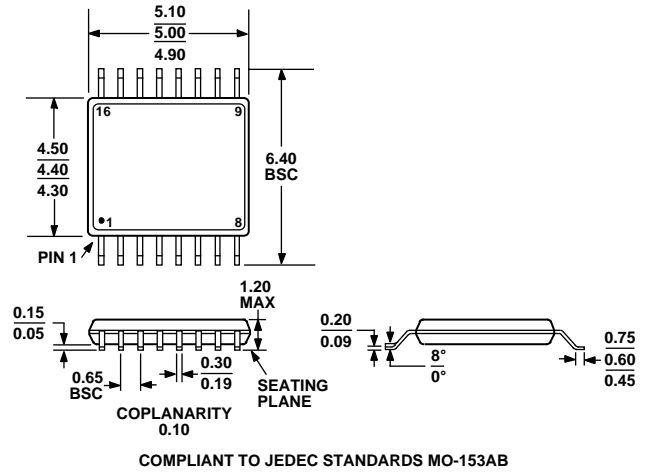

Figure 31. 16-Lead Thin Shrink Small Outline Package [TSSOP]  
(RU-16)  
Dimensions shown in millimeters

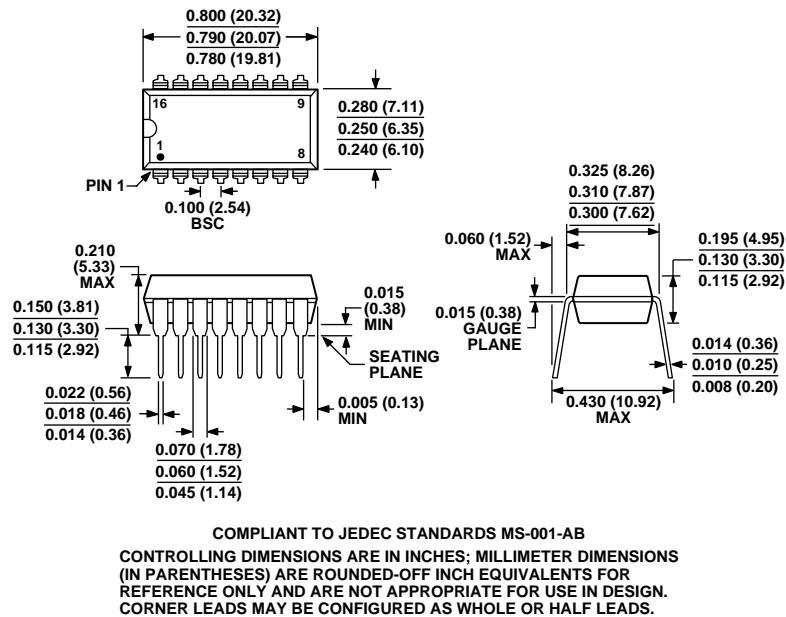

Figure 32. 16-Lead Plastic Dual In-Line Package [PDIP]  
Narrow Body  
(N-16)  
Dimensions shown in inches and (millimeters)

**ORDERING GUIDE**

<b>Model</b>	<b>Temperature Range</b>	<b>Package Description</b>	<b>Package Option</b>
AD7705BN	-40°C to +85°C	16-Lead Plastic DIP	N-16
AD7705BR	-40°C to +85°C	16-Lead SOIC	R-16
AD7705BR-REEL	-40°C to +85°C	16-Lead SOIC	R-16
AD7705BR-REEL7	-40°C to +85°C	16-Lead SOIC	R-16
AD7705BRZ <sup>1</sup>	-40°C to +85°C	16-Lead SOIC	R-16
AD7705BRZ-REEL <sup>1</sup>	-40°C to +85°C	16-Lead SOIC	R-16
AD7705BRZ-REEL7 <sup>1</sup>	-40°C to +85°C	16-Lead SOIC	R-16
AD7705BRU	-40°C to +85°C	16-Lead TSSOP	RU-16
AD7705BRU-REEL	-40°C to +85°C	16-Lead TSSOP	RU-16
AD7705BRU-REEL7	-40°C to +85°C	16-Lead TSSOP	RU-16
AD7705BRUZ <sup>1</sup>	-40°C to +85°C	16-Lead SOIC	R-16
AD7705BRUZ-REEL <sup>1</sup>	-40°C to +85°C	16-Lead SOIC	R-16
AD7705BRUZ-REEL7 <sup>1</sup>	-40°C to +85°C	16-Lead SOIC	R-16
EVAL-AD7705EB		Evaluation Board	
AD7706BN	-40°C to +85°C	16-Lead Plastic DIP	N-16
AD7706BR	-40°C to +85°C	16-Lead SOIC	R-16
AD7706BR-REEL	-40°C to +85°C	16-Lead SOIC	R-16
AD7706BR-REEL7	-40°C to +85°C	16-Lead SOIC	R-16
AD7706BRU	-40°C to +85°C	16-Lead TSSOP	RU-16
AD7706BRU-REEL	-40°C to +85°C	16-Lead TSSOP	RU-16
AD7706BRU-REEL7	-40°C to +85°C	16-Lead TSSOP	RU-16
AD7706BRUZ <sup>1</sup>	-40°C to +85°C	16-Lead TSSOP	RU-16
AD7706BRUZ-REEL <sup>1</sup>	-40°C to +85°C	16-Lead TSSOP	RU-16
AD7706BRUZ-REEL7 <sup>1</sup>	-40°C to +85°C	16-Lead TSSOP	RU-16
EVAL-AD7706EB		Evaluation Board	

<sup>1</sup> Z = Pb-free part.

**AD7705/AD7706**

**NOTES**